



# Nebraska's Energy Code: The Latest in Commercial Energy Codes

Nebraska Energy Code Training Program

Instructor: Matt Belcher

February 21, 2024: 11:00 AM– 12:30 PM CST



# Housekeeping

- Attendees are muted upon entry
- Enter questions in the chat box
- This training is being recorded
- Slides and recording will be emailed to attendees and posted on the MEEA website
- CEUs are provided (ICC and AIA)
- Email John at [jgossman@mwalliance.org](mailto:jgossman@mwalliance.org) with any questions

# Midwest Energy Efficiency Alliance

The Midwest Energy Efficiency Alliance (MEEA) is a collaborative network, promoting energy efficiency to optimize energy generation, reduce consumption, create jobs and decrease carbon emissions in all Midwest communities.

MEEA is a non-profit membership organization with 150+ members, including:



Energy service  
companies &  
contractors

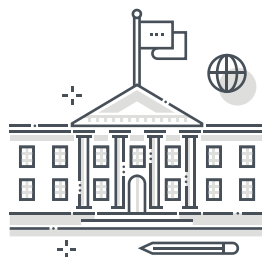

State & local  
governments



Academic &  
research institutions

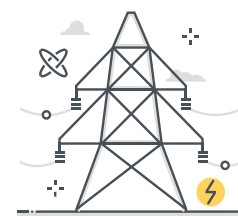

Electric &  
gas utilities

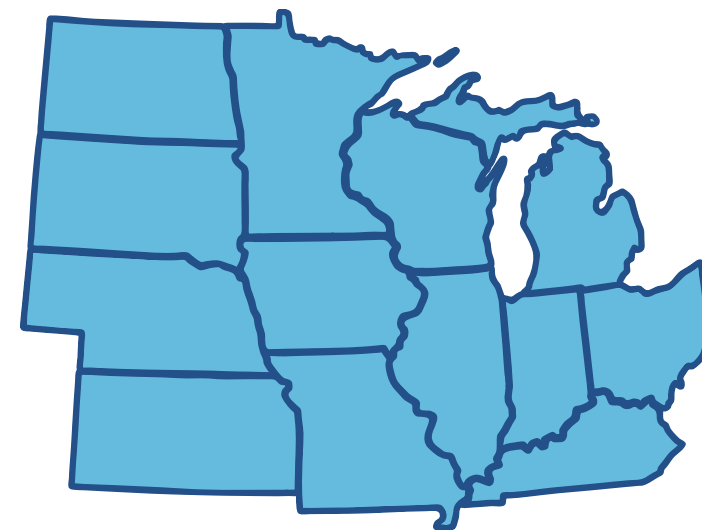

# About the Nebraska Training Program

- Goal: prepare the Nebraska workforce for upcoming changes in construction best practices
  - Residential and Commercial Energy Code
  - Building Science
  - Practical Solutions
- Focused on providing training to builders, code officials, design professionals, public officials and students
- For more information, visit:  
<https://www.mwalliance.org/nebraska-energy-codes-training-program>





# Learning Objectives

This interactive training will provide an overview of updates in the 2018 IECC and look beyond to the 2021 IECC and 2024 IECC.

In this course you will:

1. Learn about the requirements of the 2018 IECC
2. Learn about the requirements of the 2021 IECC
3. Understand what is coming in the 2024 IECC and potential requirements
4. Understand the changes between the 2018 IECC and later versions of the energy code and how that will affect development in Nebraska

# Energy Code Background

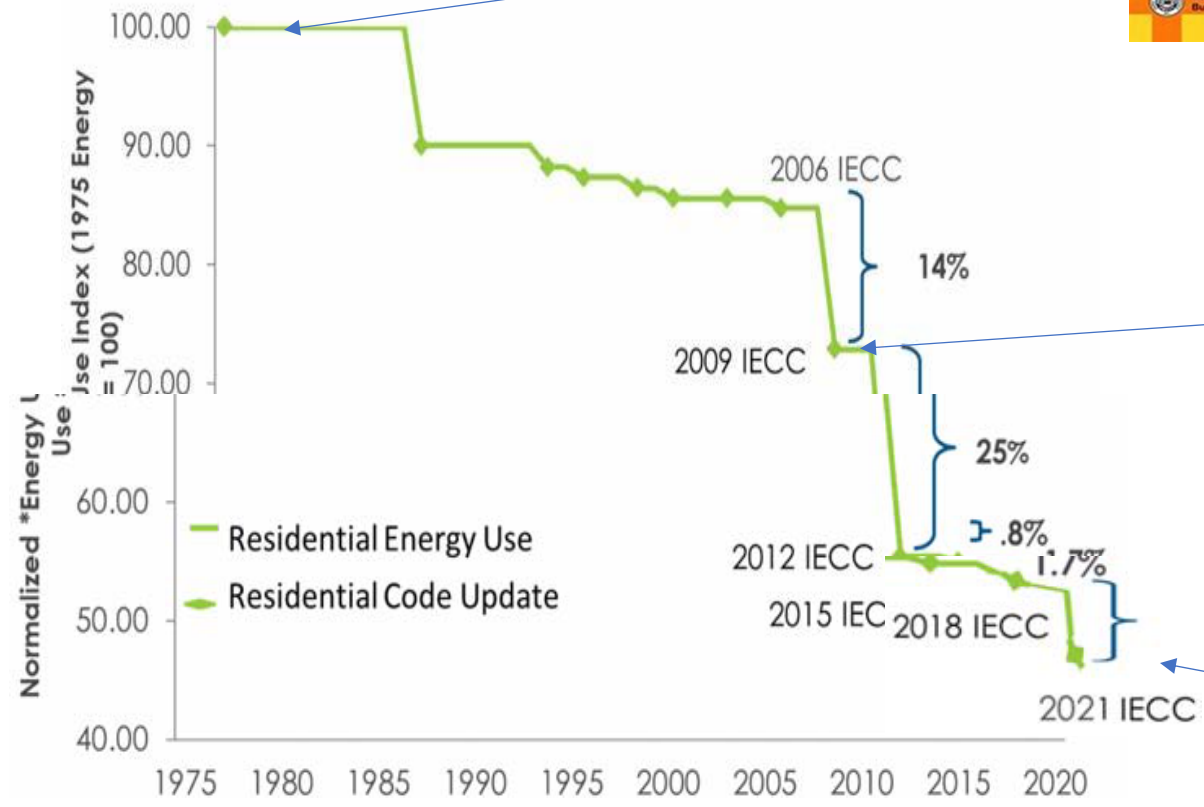
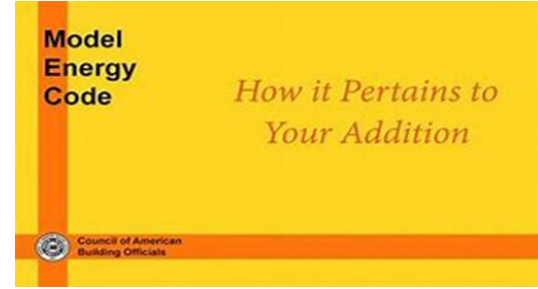

# The Energy Code is Everywhere

- Unlike most other codes, the energy code directly impacts the work of many disparate building trades and systems, including:
  - Framing/Envelope
  - Plumbing
  - HVAC
  - Electric
  - Moisture management
  - Concrete
  - Caulking





# Commercial Energy Codes



Photo: Jonathan Hillyer,





# Biggest Changes in IECC 2021

- Redrawn Climate Zones (6 CZ's in MO) Nebraska unaffected
- ASHRAE 90.1 2019 = Alternate Path
- Improved Window U-factors & Wall and Ceiling R-values
- Updated Mechanical/Lighting requirements
- Controls!
- Must choose your Additional Efficiency Package
- Increased Alternative Methods
- ComCheck
- More Focus on Commissioning



# Changes in IECC 2021



- **Administrative**
- C102: More Authority for Code Official to approve alternative material(s). (or not!)
- More definition for Code Officials Approval of Above Code Programs. (or not!)
- Information on Construction Documents must include: Energy Compliance Path and Air Sealing Details and Location of Air Barrier.



# Changes in IECC 2021

- **Definitions Added/Modified:**

- BioGas
- *Biomass*
- *Data Center/Computer Room*
- Direct Digital Control (DDC)
- Enthalpy Recovery Ratio
- Fans: Many Additions and Changes (Energy/Power, Number, etc.)
  - Large Diameter Fans
- Fault Detection and Diagnostics (FDD) System



# Changes in IECC 2021

- **Definitions Added/Modified:**
  - *Lighting Definition Modification*
  - Information Technology Equipment (ITE)
  - Internal Curtain System
  - *On-Site Renewable Energy*
  - *Renewable Energy Resources*
  - *Testing Unit Enclosure Area*
  - *Thermal Distribution Efficiency (TDE)*
  - *Vegetative Roof*
  - *Visible Transmittance*



# Old 2018 IECC climate zones

MO is CZ4-5

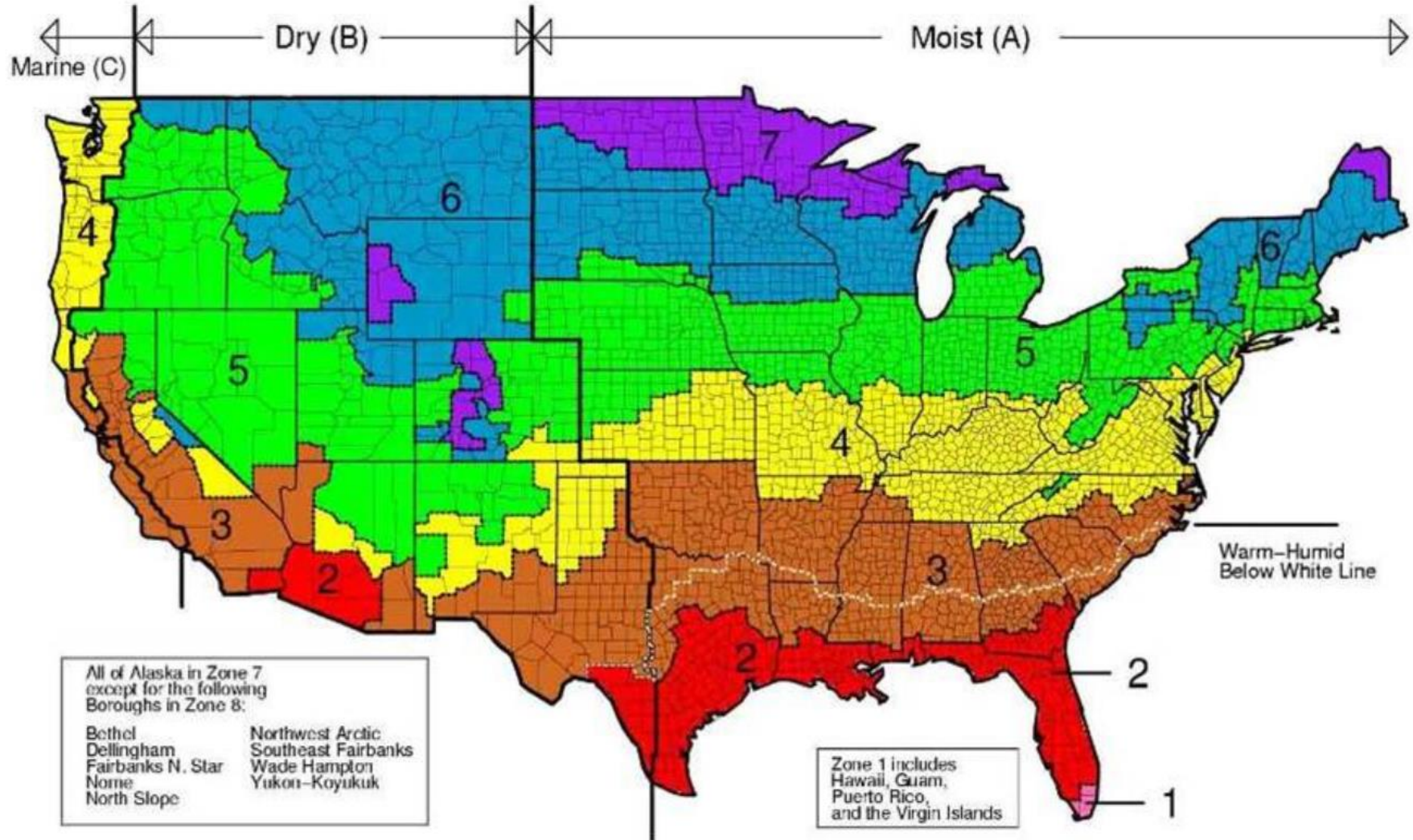

All of Alaska in Zone 7 except for the following Boroughs in Zone 8:

|                   |                     |
|-------------------|---------------------|
| Bethel            | Northwest Arctic    |
| Dellingham        | Southeast Fairbanks |
| Fairbanks N. Star | Wade Hampton        |
| Nome              | Yukon-Koyukuk       |
| North Slope       |                     |

Zone 1 includes Hawaii, Guam, Puerto Rico, and the Virgin Islands

# How are envelope requirements determined?

Requirements for building energy codes are linked to the dominate climate within a given jurisdiction, determined by a 30-year average of local surface observations.

Note: Climate zones change! Climate zones change! ASHRAE 90.1-2019 & IECC 2021 have important changes, including a new climate zone (CZ0) and shifts in county designations.

Question: Why should you (or a building owner/operator) care?

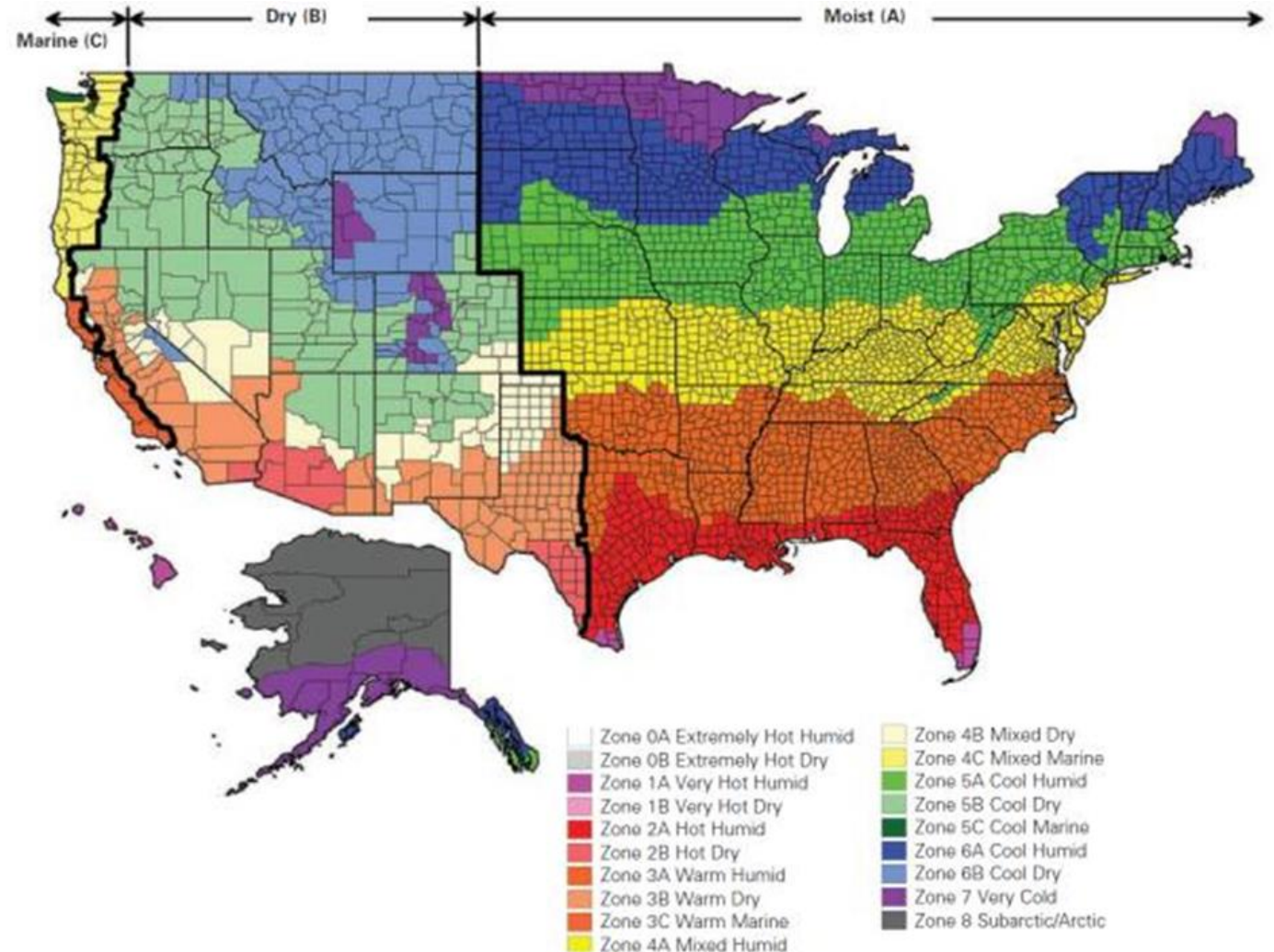

# Two Commercial Compliance Options (new in 2018)

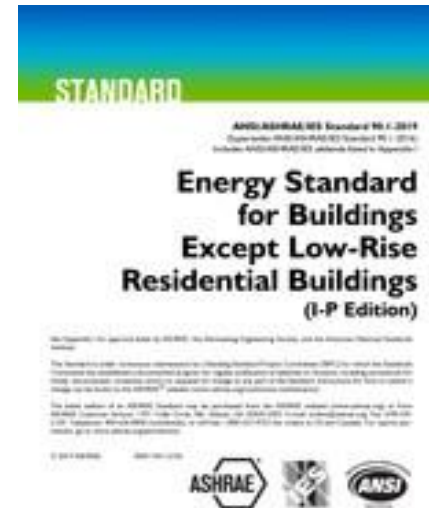
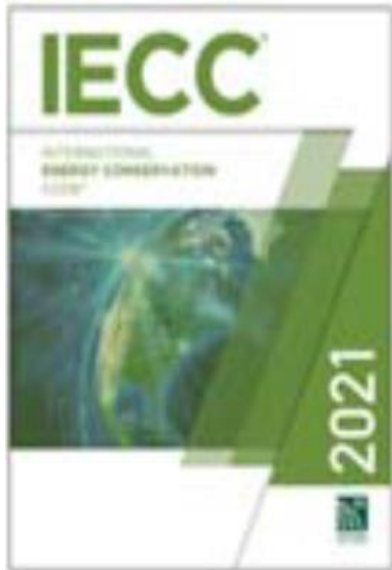

ASHRAE 90.1-2019

Alternative Method to IECC

# C401

## Thermal Envelope Certificate Required

- Completed by an *Approved Party*
- Posted on a wall in the space where space conditioning equipment is located
- Shows R-Values, U-Values, Envelope Leakage Test Results, Etc.

### In Addition:

- Updates to Greenhouse Requirements.
- More Insulation Installation requirements.

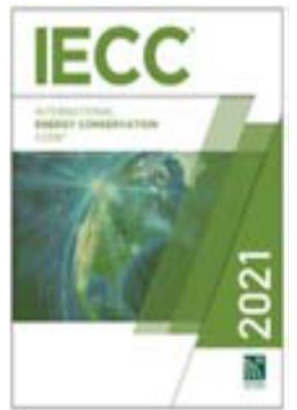



# C402 What is the Building Thermal Envelope?

- These assemblies can comprise the building thermal envelope if they **separate conditioned from unconditioned space or outside air**
  - Roof/Ceiling Assembly
  - Wall Assembly
  - Vertical Fenestration and Skylight
  - Floor Assembly
  - Slab Edge
  - Below-Grade Wall Assembly

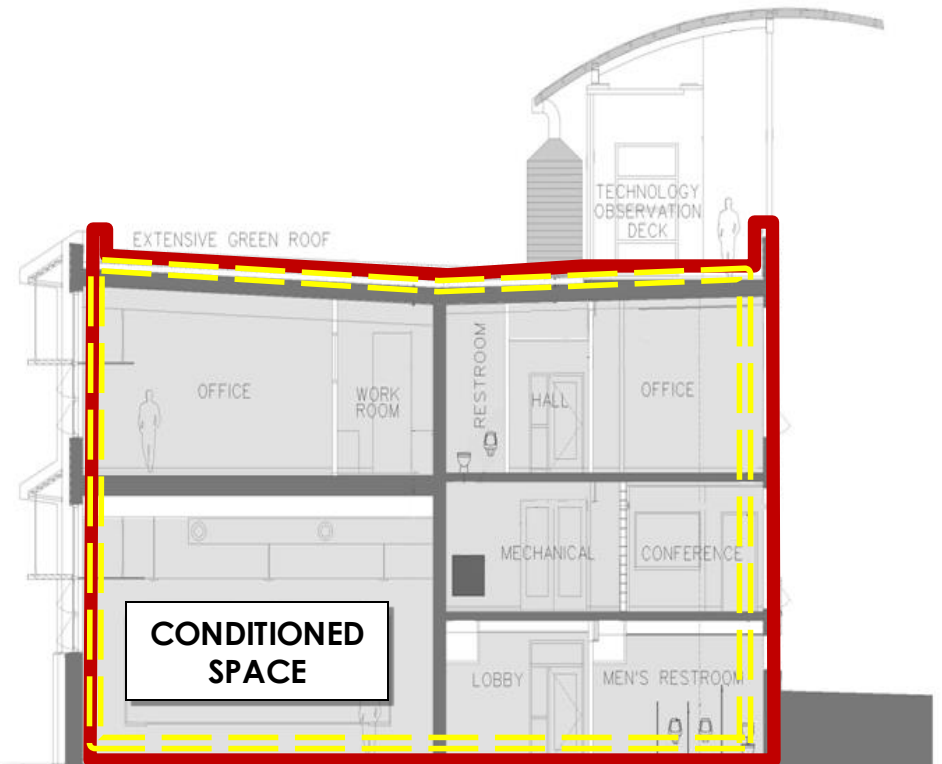

# Space Conditioning Categories

- Envelope requirements are specified by space-conditioning categories
- Conditioned space must be:
  - a cooled space with a cooling system sensible cooling output capacity larger than 3.4 Btu/h·ft<sup>2</sup> of floor area
  - a heated space with a heating system output capacity larger than that specified in table provided
  - Or, an indirectly conditioned space

| Heating Output, Btu/h·ft <sup>2</sup> | Climate Zone |
|---------------------------------------|--------------|
| >5                                    | 0, 1, 2      |
| >9                                    | 3A, 3B       |
| >7                                    | 3C           |
| >10                                   | 4A, 4B       |
| >8                                    | 4C           |
| >12                                   | 5            |
| >14                                   | 6            |
| >16                                   | 7            |
| >19                                   | 8            |

# Space Conditioning Categories

Separate envelope component requirements apply to three types of conditioned spaces

- 90.1: *Nonresidential* – IECC: “All other”
- 90.1: *Residential* – IECC: “Group R”
- 90.1: *Semiheated* – spaces are heated, but not to comfort levels, and not cooled.  
(Only if approved by the building official - Uncommon)

# Semi-Exterior Envelope

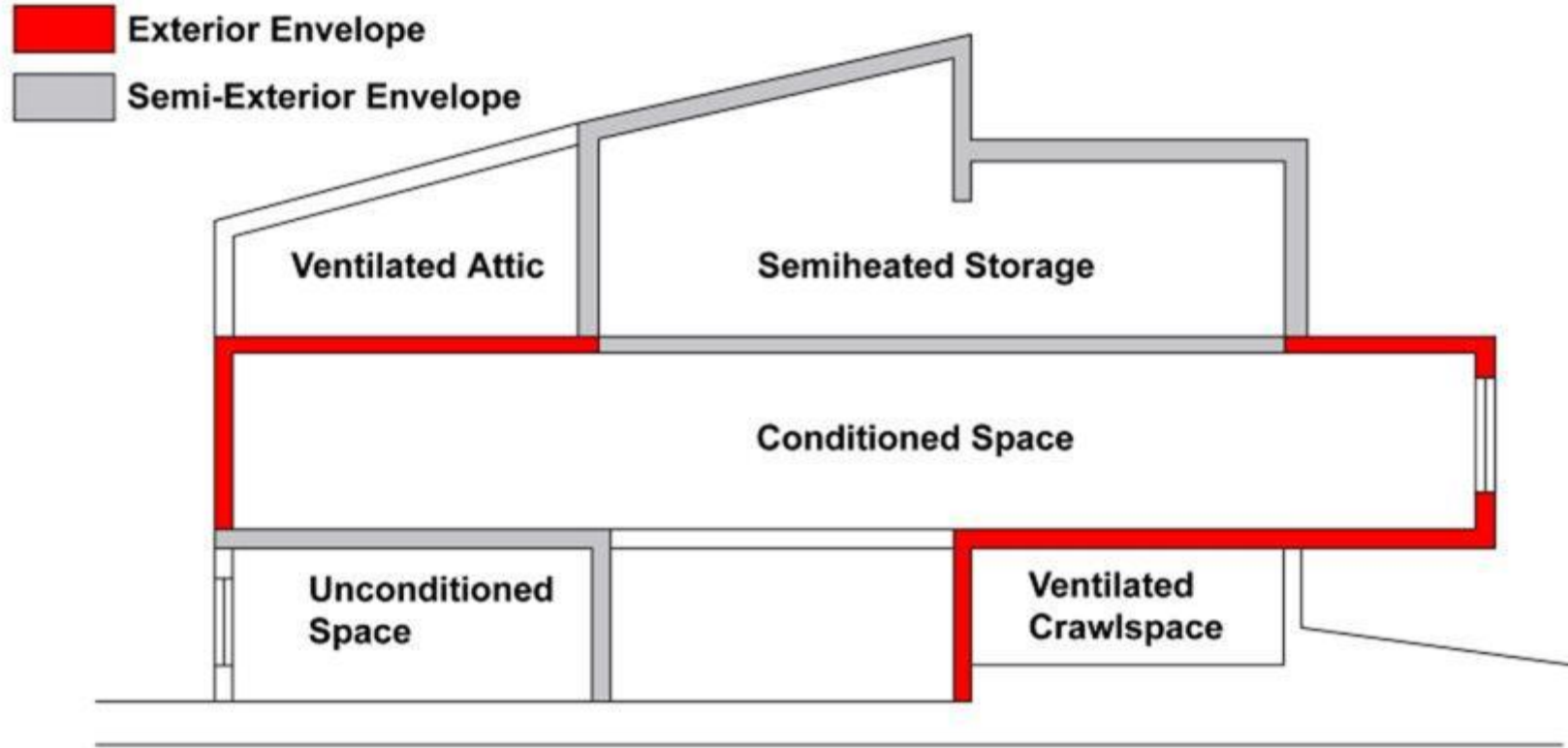

*\*IECC does not have a definition for semiheated*

# Space Conditioning Categories

A semiheated space has a heating system with a capacity  $\geq 3.4 \text{ Btu/h.ft}^2$  of floor area but is not conditioned space

Spaces are assumed to be conditioned space and comply with requirements of conditioned space at time of construction regardless of whether the mechanical or electrical equipment is included in the building permit application or installed at that time

## Exceptions:

- Space is designated as semiheated or unconditioned and approved as such by the building official

# Compliance Options

- Mandatory provisions apply to all compliance pathways
- Prescriptive is a recipe that you have to follow
- Other pathways require energy modeling

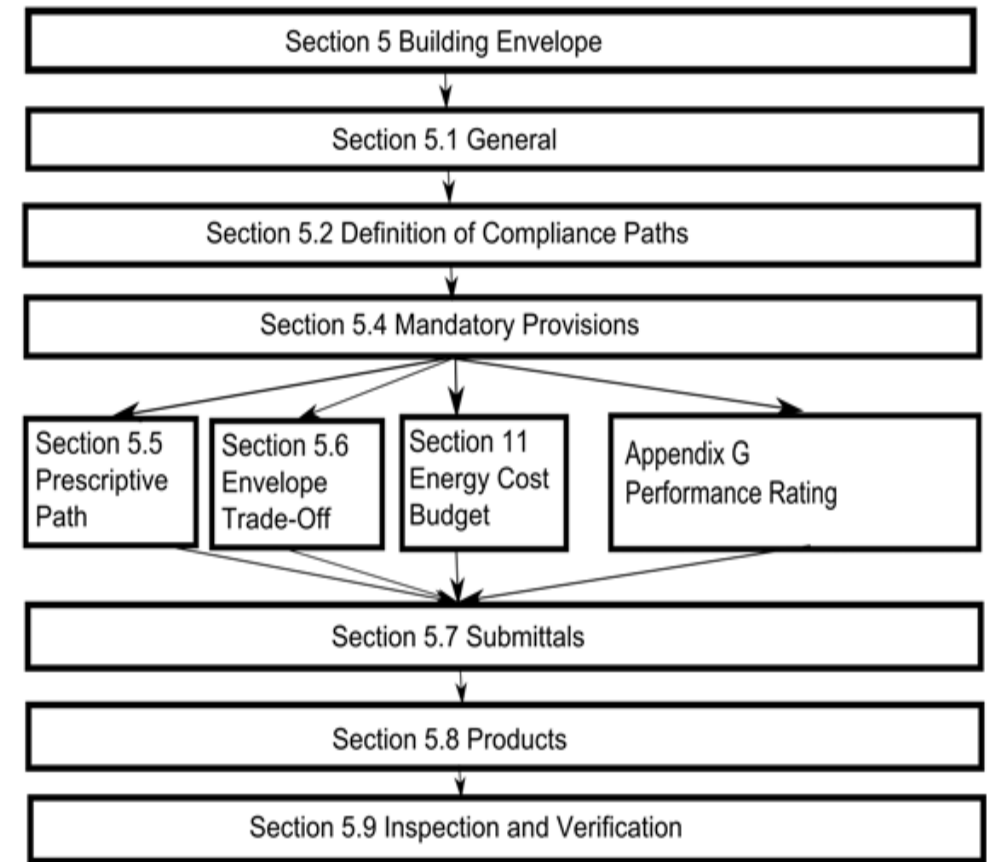

# Compliance Options - Prescriptive

- Building must comply with
  - C402 Envelope
  - C403 Mech
  - C404 SWH
  - C405 Lighting
  - Plus pick one additional efficiency package

# Additional Efficiency Package Options

- One additional efficiency feature must be selected to comply with the IECC
- C406.2 More efficient **HVAC** performance, OR
- C406.3 Reduced **lighting** power density system, OR
- C406.4 Enhanced lighting **controls**, OR
- C406.5 On-site supply of **renewable** energy
- C406.6 Dedicated outdoor air system (**DOAS**), OR
- C406.7 More efficient SWH (**hot water**) OR
- C406.8 Enhanced **envelope** performance OR
- C406.9 Reduced air **infiltration**



# Compliance Options - Performance

- C407 Total Building Performance
- Building energy cost to be less than 85% of standard reference design building
- C402.5 Air Leakage
- C403.2 Provisions applicable to all mechanical
- C404 SWH
- Mandatory Lighting C405.2, C405.3, C405.4, C405.6



# Insulation – Prescriptive Requirements



# Mandatory Provisions - Insulation

- Insulation must be in substantial contact with inside surface in a permanent manner
- No loose-fill insulation in attic when ceiling is steeper than 3:12 slope
- Dams & baffles at eave vents to deflect incoming air
- Recessed equipment – effect on insulation
- Insulation protected from sunlight, moisture, landscaping operations, equipment maintenance, and wind
- Stagger joints of multilayered rigid insulation

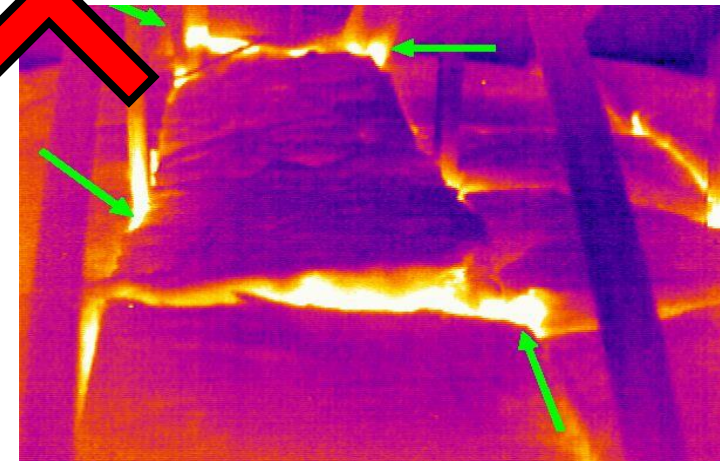

TABLE C402.1.3 OPAQUE THERMAL ENVELOPE INSULATION COMPONENT MINIMUM REQUIREMENTS, R-VALUE METHOD<sup>a</sup>



| CLIMATE ZONE                        | 0 AND 1                             |                                     | 2                                   |                                     | 3                                  |                                    | 4 EXCEPT MARINE                    |                                    | 5 AND MARINE 4                     |                                    | 6                                  |                                    | 7                                  |                                    |
|-------------------------------------|-------------------------------------|-------------------------------------|-------------------------------------|-------------------------------------|------------------------------------|------------------------------------|------------------------------------|------------------------------------|------------------------------------|------------------------------------|------------------------------------|------------------------------------|------------------------------------|------------------------------------|
|                                     | All other                           | Group R                             | All other                           | Group R                             | All other                          | Group R                            | All other                          | Group R                            | All other                          | Group R                            | All other                          | Group R                            | All other                          | Group R                            |
| <b>Roofs</b>                        |                                     |                                     |                                     |                                     |                                    |                                    |                                    |                                    |                                    |                                    |                                    |                                    |                                    |                                    |
| Insulation entirely above roof deck | R-20ci                              | R-25ci                              | R-25ci                              | R-25ci                              | R-25ci                             | R-25ci                             | R-30ci                             | R-30ci                             | R-30ci                             | R-30ci                             | R-30ci                             | R-30ci                             | R-35ci                             | R-35ci                             |
| Metal buildings <sup>b</sup>        | R-19 + R-11 LS                      | R-19 + R-11 LS                      | R-19 + R-11 LS                      | R-19 + R-11 LS                      | R-19 + R-11 LS                     | R-19 + R-11 LS                     | R-19 + R-11 LS                     | R-19 + R-11 LS                     | R-19 + R-11 LS                     | R-19 + R-11 LS                     | R-25 + R-11 LS                     | R-30 + R-11 LS                     | R-30 + R-11 LS                     | R-30 + R-11 LS                     |
| Attic and other                     | R-38                                | R-38                                | R-38                                | R-38                                | R-38                               | R-38                               | R-49                               | R-49                               | R-49                               | R-49                               | R-49                               | R-49                               | R-60                               | R-60                               |
| <b>Walls, above grade</b>           |                                     |                                     |                                     |                                     |                                    |                                    |                                    |                                    |                                    |                                    |                                    |                                    |                                    |                                    |
| Mass <sup>f</sup>                   | R-5.7ci <sup>c</sup>                | R-5.7ci <sup>c</sup>                | R-5.7ci <sup>c</sup>                | R-7.6ci                             | R-7.6ci                            | R-9.5ci                            | R-9.5ci                            | R-11.4ci                           | R-11.4ci                           | R-13.3ci                           | R-13.3ci                           | R-15.2ci                           | R-15.2ci                           | R-15.2ci                           |
| Metal building                      | R-13 + R-6.5ci                      | R-13 + R-6.5ci                      | R-13 + R-6.5ci                      | R-13 + R-13ci                       | R-13 + R-6.5ci                     | R-13 + R-13ci                      | R-13 + R-13ci                      | R-13 + R-14ci                      | R-13 + R-14ci                      | R-13 + R-14ci                      | R-13 + R-14ci                      | R-13 + R-14ci                      | R-13 + R-17ci                      | R-13 + R-19.5ci                    |
| Metal framed                        | R-13 + R-5ci                        | R-13 + R-5ci                        | R-13 + R-5ci                        | R-13 + R-7.5ci                      | R-13 + R-7.5ci                     | R-13 + R-7.5ci                     | R-13 + R-7.5ci                     | R-13 + R-7.5ci                     | R-13 + R-10ci                      | R-13 + R-10ci                      | R-13 + R-12.5ci                    | R-13 + R-12.5ci                    | R-13 + R-12.5ci                    | R-13 + R-15.6ci                    |
| Wood framed and other               | R-13 + R-3.8ci or R-20              | R-13 + R-3.8ci or R-20              | R-13 + R-3.8ci or R-20              | R-13 + R-3.8ci or R-20              | R-13 + R-3.8ci or R-20             | R-13 + R-3.8ci or R-20             | R-13 + R-3.8ci or R-20             | R-13 + R-3.8ci or R-20             | R-13 + R-7.5ci or R-20 + R-3.8ci   | R-13 + R-7.5ci or R-20 + R-3.8ci   | R-13 + R-7.5ci or R-20 + R-3.8ci   | R-13 + R-7.5ci or R-20 + R-3.8ci   | R-13 + R-7.5ci or R-20 + R-3.8ci   | R-13 + R-7.5ci or R-20 + R-3.8ci   |
| <b>Walls, below grade</b>           |                                     |                                     |                                     |                                     |                                    |                                    |                                    |                                    |                                    |                                    |                                    |                                    |                                    |                                    |
| Below-grade wall <sup>d</sup>       | NR                                  | NR                                  | NR                                  | NR                                  | NR                                 | NR                                 | R-7.5ci                            | R-10ci                             | R-7.5ci                            | R-10ci                             | R-10ci                             | R-15ci                             | R-15ci                             | R-15ci                             |
| <b>Floors</b>                       |                                     |                                     |                                     |                                     |                                    |                                    |                                    |                                    |                                    |                                    |                                    |                                    |                                    |                                    |
| Mass <sup>e</sup>                   | NR                                  | NR                                  | R-6.3ci                             | R-8.3ci                             | R-10ci                             | R-10ci                             | R-14.6ci                           | R-16.7ci                           | R-14.6ci                           | R-16.7ci                           | R-16.7ci                           | R-16.7ci                           | R-20.9ci                           | R-20.9ci                           |
| Joist/framing                       | R-13                                | R-13                                | R-30                                | R-30                                | R-30                               | R-30                               | R-30                               | R-30                               | R-30                               | R-30                               | R-30                               | R-38                               | R-38                               | R-38                               |
| <b>Slab-on-grade floors</b>         |                                     |                                     |                                     |                                     |                                    |                                    |                                    |                                    |                                    |                                    |                                    |                                    |                                    |                                    |
| Unheated slabs                      | NR                                  | NR                                  | NR                                  | NR                                  | NR                                 | R-10 for 24" below                 | R-15 for 24" below                 | R-15 for 24" below                 | R-15 for 24" below                 | R-20 for 24" below                 | R-20 for 24" below                 | R-20 for 48" below                 | R-20 for 24" below                 | R-20 for 48" below                 |
| Heated slabs <sup>g</sup>           | R-7.5 for 12" below + R-5 full slab | R-7.5 for 12" below + R-5 full slab | R-7.5 for 12" below + R-5 full slab | R-7.5 for 12" below + R-5 full slab | R-10 for 24" below + R-5 full slab | R-10 for 24" below + R-5 full slab | R-15 for 24" below + R-5 full slab | R-15 for 24" below + R-5 full slab | R-15 for 36" below + R-5 full slab | R-15 for 36" below + R-5 full slab | R-15 for 36" below + R-5 full slab | R-20 for 48" below + R-5 full slab | R-20 for 48" below + R-5 full slab | R-20 for 48" below + R-5 full slab |



# Ashrae 90.1-2019 envelope requirements Climate Zone 4



Table 5.5-4 Building Envelope Requirements for Climate Zone 4 (A,B,C)\*

| Opaque Elements                       | Nonresidential   |                                 | Residential      |                                 | Semiheated       |                         |
|---------------------------------------|------------------|---------------------------------|------------------|---------------------------------|------------------|-------------------------|
|                                       | Assembly Maximum | Insulation Min. R-Value         | Assembly Maximum | Insulation Min. R-Value         | Assembly Maximum | Insulation Min. R-Value |
| <i>Roofs</i>                          |                  |                                 |                  |                                 |                  |                         |
| <i>Insulation entirely above deck</i> | U-0.032          | R-30 c.i.                       | U-0.032          | R-30 c.i.                       | U-0.093          | R-10 c.i.               |
| <i>Metal building<sup>a</sup></i>     | U-0.037          | R-19 + R-11 Ls or R-25 + R-8 Ls | U-0.037          | R-19 + R-11 Ls or R-25 + R-8 Ls | U-0.082          | R-19                    |
| <i>Attic and other</i>                | U-0.021          | R-49                            | U-0.021          | R-49                            | U-0.034          | R-30                    |
| <i>Walls, above Grade</i>             |                  |                                 |                  |                                 |                  |                         |
| <i>Mass</i>                           | U-0.104          | R-9.5 c.i.                      | U-0.090          | R-11.4 c.i.                     | U-0.580          | NR                      |
| <i>Metal building</i>                 | U-0.060          | R-0 + R-15.8 c.i.               | U-0.050          | R-0 + R-19 c.i.                 | U-0.162          | R-13                    |
| <i>Steel-framed</i>                   | U-0.064          | R-13 + R-7.5 c.i.               | U-0.064          | R-13 + R-7.5 c.i.               | U-0.124          | R-13                    |
| <i>Wood-framed and other</i>          | U-0.064          | R-13 + R-3.8 c.i. or R-20       | U-0.064          | R-13 + R-3.8 c.i. or R-20       | U-0.089          | R-13                    |
| <i>Wall, below Grade</i>              |                  |                                 |                  |                                 |                  |                         |
| <i>Below-grade wall</i>               | C-0.119          | R-7.5 c.i.                      | C-0.092          | R-10 c.i.                       | C-1.140          | NR                      |
| <i>Floors</i>                         |                  |                                 |                  |                                 |                  |                         |
| <i>Mass</i>                           | U-0.057          | R-14.6 c.i.                     | U-0.051          | R-16.7 c.i.                     | U-0.107          | R-6.3 c.i.              |
| <i>Steel joist</i>                    | U-0.038          | R-30                            | U-0.038          | R-30                            | U-0.052          | R-19                    |
| <i>Wood-framed and other</i>          | U-0.033          | R-30                            | U-0.033          | R-30                            | U-0.051          | R-19                    |
| <i>Slab-on-Grade Floors</i>           |                  |                                 |                  |                                 |                  |                         |
| <i>Unheated</i>                       | F-0.520          | R-15 for 24 in.                 | F-0.520          | R-15 for 24 in.                 | F-0.730          | NR                      |
| <i>Heated</i>                         | F-0.843          | R-20 for 24 in.                 | F-0.688          | R-20 for 48 in.                 | F-0.900          | R-10 for 24 in.         |
| <i>Opaque Doors</i>                   |                  |                                 |                  |                                 |                  |                         |
| <i>Swinging</i>                       | U-0.370          |                                 | U-0.370          |                                 | U-0.370          |                         |
| <i>Nonswinging</i>                    | U-0.310          |                                 | U-0.310          |                                 | U-0.360          |                         |

# Metal Building Roof Insulation

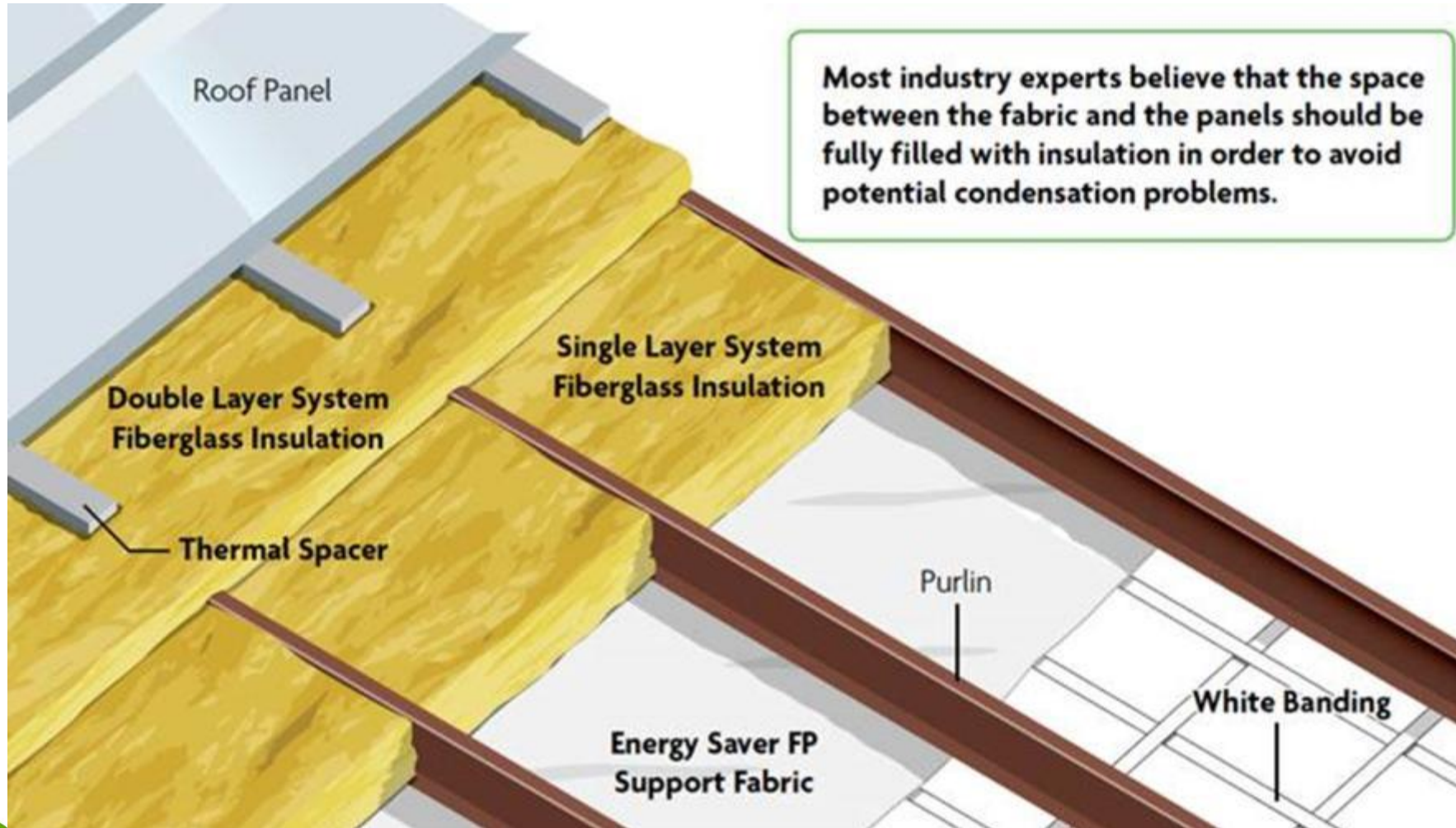

Most industry experts believe that the space between the fabric and the panels should be fully filled with insulation in order to avoid potential condensation problems.



# IBC 806.5 unvented roof assemblies

- To reduce risk of condensation, install a certain amount of “air-impermeable” insulation before using an “air-permeable” product in an unvented roof assembly

**TABLE R806.5  
INSULATION FOR CONDENSATION CONTROL**

| CLIMATE ZONE             | MINIMUM RIGID BOARD ON AIR-IMPERMEABLE INSULATION <i>R</i> -VALUE <sup>a, b</sup> |
|--------------------------|---|
| 2B and 3B tile roof only | 0 (none required)   |
| 1, 2A, 2B, 3A, 3B, 3C    | R-5   |
| 4C                       | R-10  |
| 4A, 4B                   | R-15  |
| 5                        | R-20  |
| 6                        | R-25  |
| 7                        | R-30  |
| 8                        | R-35  |

a. Contributes to but does not supersede the requirements in Section N1102.

b. Alternatively, sufficient continuous insulation shall be installed directly above the structural roof sheathing to maintain the monthly average temperature of the underside of the structural roof sheathing above 45°F (7°C). For calculation purposes, an interior air temperature of 68°F (20°C) is assumed and the exterior air temperature is assumed to be the monthly average outside air temperature of the three coldest months.



# Table 5.5.3.1.1 – Increased Roof Insulation Values

| <i>Roofs</i>                          | <i>Nonresidential</i>   |                                | <i>Residential</i>      |                                |
|---------------------------------------|-------------------------|--------------------------------|-------------------------|--------------------------------|
| <i>Opaque Elements</i>                | <i>Assembly Maximum</i> | <i>Insulation Min. R-Value</i> | <i>Assembly Maximum</i> | <i>Insulation Min. R-Value</i> |
| <b>Climate Zone 0</b>                 |                         |                                |                         |                                |
| <i>Insulation entirely above deck</i> | U-0.027                 | R-36 c.i.                      | U-0.027                 | R-36 c.i.                      |
| <i>Metal buildings</i>                | U-0.028                 | R-35                           |                         |                                |
| <b>Climate Zones 1 to 3</b>           |                         |                                |                         |                                |
| <i>Insulation entirely above deck</i> | U-0.030                 | R-33 c.i.                      | U-0.029                 | R-34 c.i.                      |
| <i>Metal buildings</i>                | U-0.028                 | R-35                           |                         |                                |



# Air Barrier Location now required on Construction Docs. (C102)

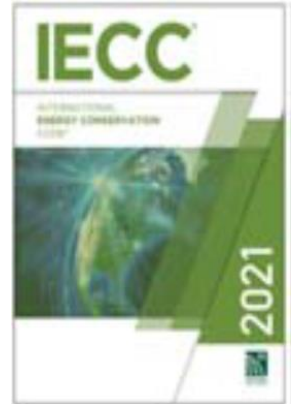

# Continuous Air Barrier

**Continuous** air barrier required except in:

- Semiheated spaces in climate zones 0-6
- Single wythe concrete masonry buildings in climate zone 2B
- **The air barrier shall be designed and noted**
- *Air barrier components identified or noted in construction documents*
- Joints, intersections, and penetrations of air barrier components (incl. lighting fixtures) detailed
- Air barrier must extend over all surfaces of building envelope at lowest floor, exterior walls, and ceiling or roof
- Designed to resist positive and negative pressures from wind, stack effect, and mechanical ventilation

# Air barrier materials

- Materials that have an air permeance not exceeding 0.004 cfm/ft<sup>2</sup> under a pressure differential of 0.3 in. of water (1.57 psf) when tested in accordance with ASTM E2178. The following materials meet these requirements:

| Material   | Thickness (minimum) |
|--|---------------------|
| Plywood  | 3/8 in.             |
| Oriented strand board  | 3/8 in.             |
| Extruded polystyrene insulation board                                    | 1/2 in.             |
| Foil-faced urethane insulation board                                     | 1/2 in.             |
| Exterior gypsum sheathing or interior gypsum board                       | 1/2 in.             |
| Cement board   | 1/2 in.             |
| Built up roofing membrane  |                     |
| Modified bituminous roof membrane  |                     |
| Single-ply roof membrane   |                     |
| A Portland cement/sand parge, stucco, or gypsum plaster                  | 1/2 in.             |
| Cast-in-place and precast concrete                                       |                     |
| Sheet metal  |                     |
| Closed cell 2 lb/ft <sup>3</sup> nominal density spray polyurethane foam | 1 in.               |

# Air Barrier Installation

The following areas are to be wrapped, sealed, caulked, gasketed, or taped:

- Joints around fenestration and door frames (both manufactured and site-built)
- Junctions between walls
  - And foundations
  - At building corners
  - And roofs or ceilings
- Penetrations for roofs, walls, and floors
- Building assemblies used as ducts or plenums
- Joints, seams, connections between planes, and other changes in continuous air barrier materials



# Recessed equipment

Lighting fixtures; heating, ventilating, and air-conditioning equipment, including wall heaters, ducts, and plenums; and other equipment shall not be recessed in such a manner as to affect the insulation thickness unless:

- a) the total combined area affected (including necessary clearances) is less than 1% of the opaque area of the assembly,
  - b) the entire roof, wall, or floor is covered with insulation to the full depth required, or
  - c) the effects of reduced insulation are included in calculations using an area-weighted average method and compressed insulation values obtained from Table A9.4.3.
- In all cases, air leakage through or around the recessed equipment to the conditioned space shall be limited in accordance with Section 5.4.3.

# Recessed Lighting

All recessed luminaires installed in the building thermal envelope must be IC rated and have the following:

- Sealed with gasket or caulk between housing and interior wall or ceiling covering
- Labeled in accordance with ASTM E 283 to allow  $\leq 2.0$  cfm of air movement between conditioned and unconditioned spaces



# Major Air Leakage Locations

- Cavities above suspended ceilings
- Plenum return spaces (Highly depressurized)
- Ventilated walls
- Equipment tunnels and chases
- Mechanical rooms and mezzanines
- Unconditioned adjacent space (storage, plant, warehouse, etc.)





# Envelope leakage ratio @ 75 Pa “ELR75” – A better metric

- Leakage occurs through shell of building (not through volume)
- Normalizing leakage at 75Pa (0.3 in w.c.) based on shell area is most common for commercial buildings

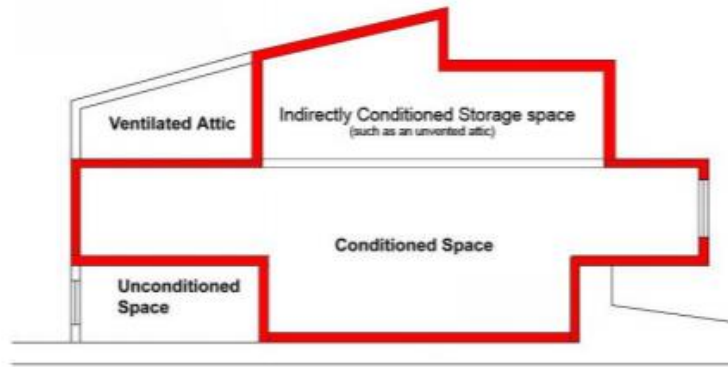

## Building Thermal Envelope

The building thermal envelope is the portion of the building envelope that is comprised of the continuous air barrier and insulation and separates conditioned space from unconditioned space.

## Example Calculation

A 7,600 square foot building (First floor: 3,600 square feet and second floor: 4,000 square feet) has a shell area of 13,920 square feet. The blower door test measures a flow of 3,340 CFM<sub>75</sub>.

What is the Envelope Leakage Ratio at 75 Pa?

ELR<sub>75</sub> is calculated by dividing the measured CFM<sub>75</sub> by the total shell area of the envelope.

$$\text{Shell Area} = 4000\text{ft}^2 + 4000\text{ft}^2 + 5920\text{ft}^2 = 13,920\text{ft}^2$$

$$\text{BD Fan Flow Measurement} = 3,340 \text{ CFM}_{75}$$

$$ELR_{75} = \frac{CFM_{75}}{\text{Shell Area}}$$

$$ELR_{75} = \frac{3,340 \text{ CFM}_{75}}{13,920 \text{ sf}}$$

$$ELR_{75} = 0.24$$

Envelope passes program requirement and earns additional points

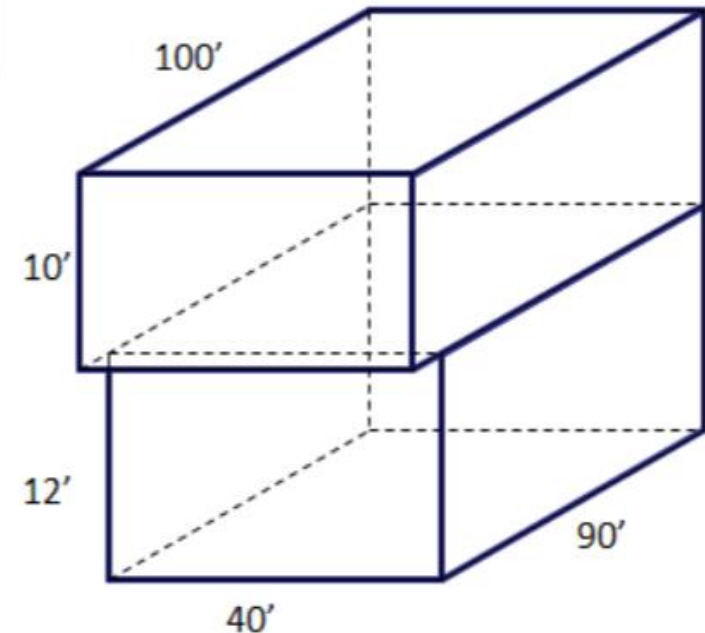

# Verifying an Energy Efficient Building Envelope

Blower Door Testing – Recognized by IECC

- Prove Air Sealing
- Envelope Integrity

**C402.5 Air leakage—thermal envelope (Mandatory).** The *thermal envelope* of buildings shall comply with Sections C402.5.1 through C402.5.8, or the building *thermal envelope* shall be tested in accordance with ASTM E 779 at a pressure differential of 0.3 inch water gauge (75 Pa) or an equivalent method approved by the code official and deemed to comply with the provisions of this section when the tested air leakage rate of the building thermal envelope is not greater than 0.40 cfm/ft<sup>2</sup> (0.2 L/s · m<sup>2</sup>). Where compliance is based on such testing, the building shall also comply with Sections C402.5.5, C402.5.6 and C402.5.7.

$$ELR_{75} = \frac{CFM_{75}}{\text{shell area}}$$

$$ELR_{75} \leq 0.40$$

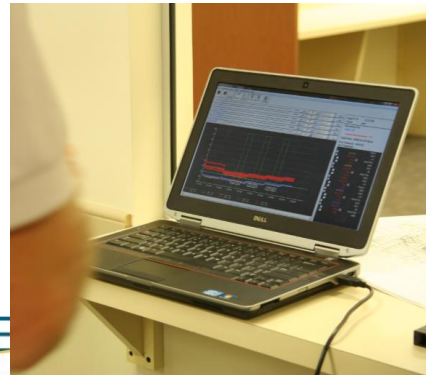

# Multi-blower door – envelope leakage test

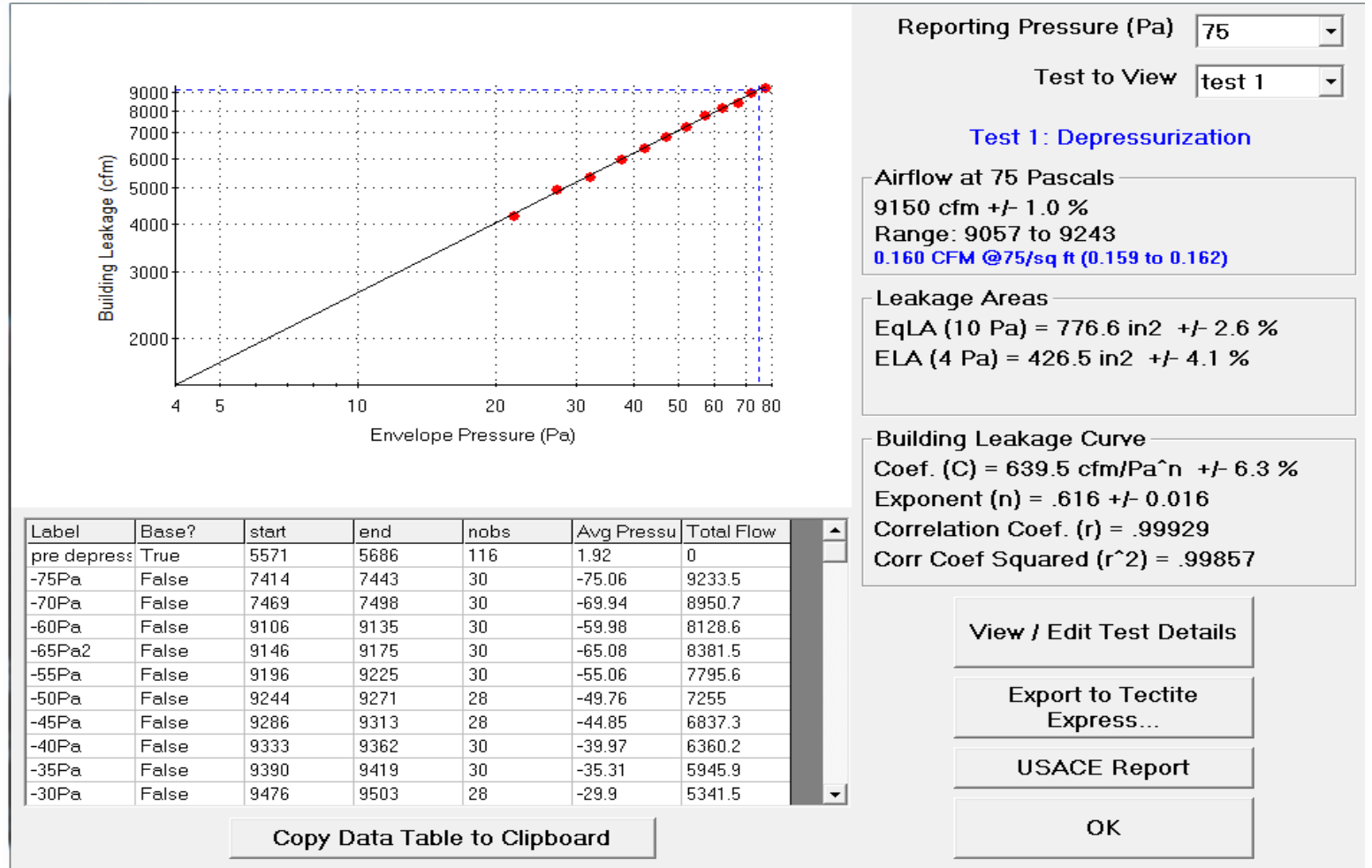

# Bonus - Reduced Air Infiltration

- Air infiltration verified by whole-building pressurization test
  - Per ASTM E779 or ASTM E1827
  - By an independent third party
- Measured air-leakage rate not to exceed **0.25 cfm/ft<sup>2</sup>** under pressure differential of 0.3 inches w.c. (75 Pa), with calculated surface area the sum of above- and below-grade building envelope
- Submit report to code official and building owner, including: tested surface area, floor area, air by volume, stories above grade, and leakage rates

**Exception:** Buildings over 250,000 ft<sup>2</sup> of conditioned floor area don't need testing on whole building, can test representative above-grade sections. Tested areas to total not less than 25% of conditioned floor area and tested per C406.9

# RTU Envelope Penetrations

Wall and roof penetration require sealing at curb and equipment

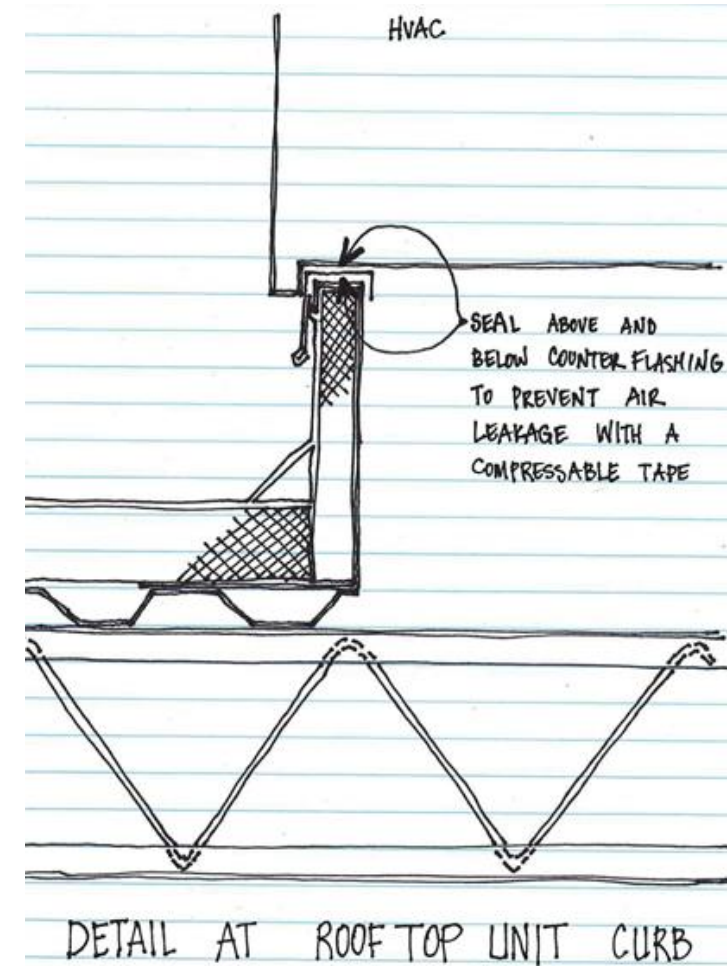

# Loading Dock Weatherseals

- Cargo and loading door openings must be equipped with weatherseals to restrict infiltration and provide direct contact with vehicles along top and sides

*Photos Courtesy of PNNL and DOE*

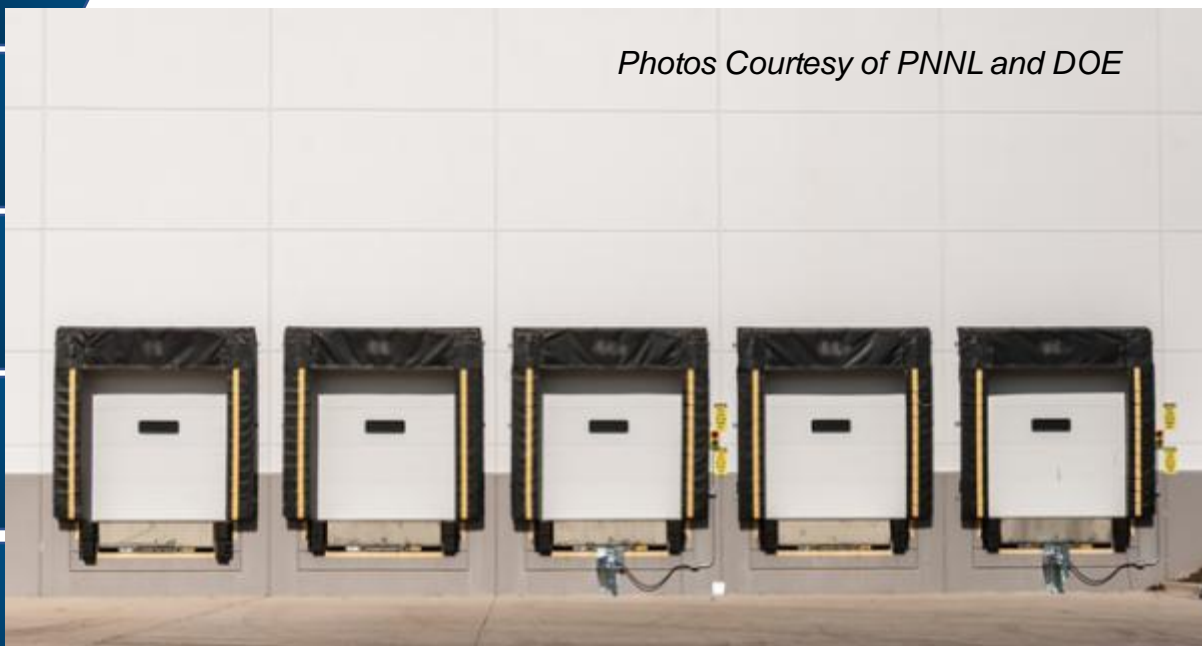

# Loading Dock Weatherseals

- **ASHRAE 90.1 2019**

Exception – Climate zones 1-3



- **IECC 2021**

No exceptions for warmer climate zones.



# Vestibules

- Required for both codes with many exceptions
- The taller the building, the greater the need for vestibules
- Both codes vary greatly on requirements based on zones and other inputs

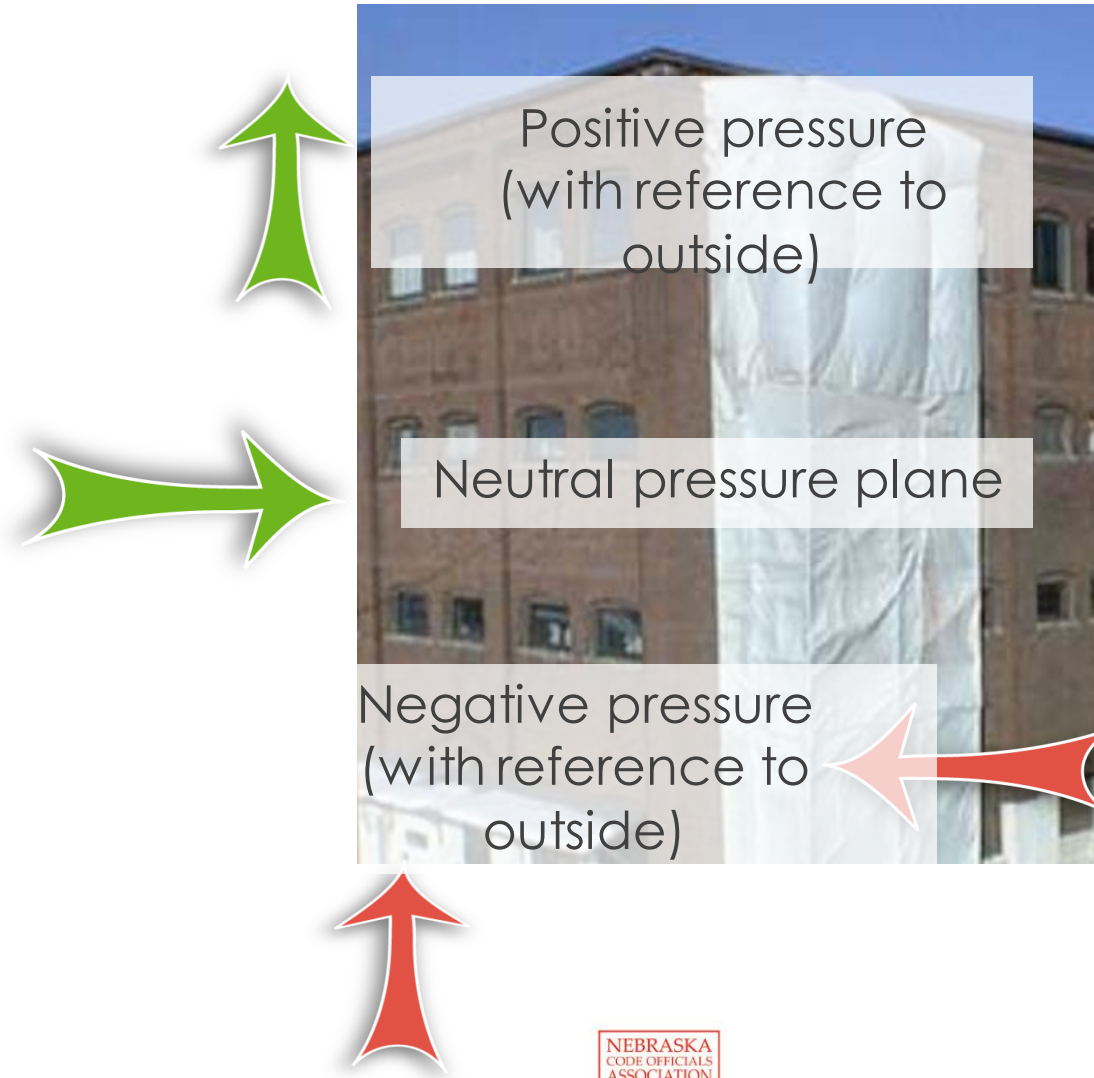



# Vestibules

- Vestibules must have
  - Self-closing doors
  - Interior and exterior doors not open at the same time
  - Distance between interior and exterior doors not  $< 7$  ft when in closed position
  - Floor area of each vestibule to not exceed the greater of  $50 \text{ ft}^2$  or  $2\%$  of the gross *conditioned floor area* for that level of the *building*
  - Exterior envelope of conditioned vestibule comply with *conditioned space* requirements
  - Interior/exterior envelope of unconditioned vestibule comply with *semiheated space* requirements

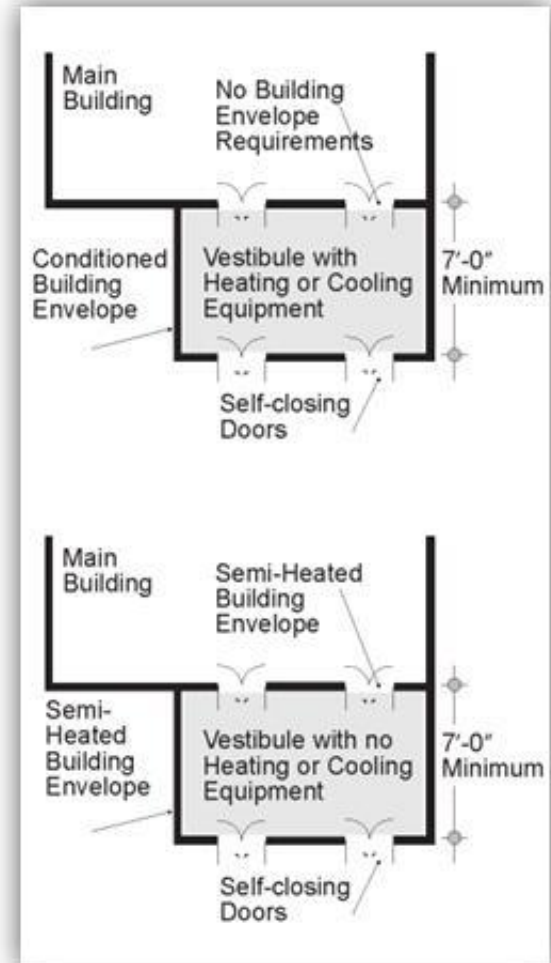

# Vestibules details

- Building entrances shall be protected with an enclosed vestibule, with all doors opening into and out of the vestibule equipped with self-closing devices. Vestibules shall be designed so that in passing through the vestibule it is not necessary for the interior and exterior doors to open at the same time. The installation of one or more revolving doors in the building entrance shall not eliminate the requirement that a vestibule be provided on any doors adjacent to revolving doors.

# Vestibules exceptions

1. Buildings in Climate Zones 1 and 2.
2. Doors not intended to be used by the public, such as doors to mechanical or electrical equipment rooms, or intended solely for employee use.
3. Doors opening directly from a sleeping unit or dwelling unit.
4. Doors that open directly from a space less than 3,000 square feet (298 m<sup>2</sup>) in area.
5. Revolving doors.
6. Doors used primarily to facilitate vehicular movement or material handling and adjacent personnel doors.
7. Doors that have an air curtain with a velocity of not less than 6.56 feet per second (2 m/s) at the floor that have been tested in accordance with ANSI/AMCA 220 and installed in accordance with the manufacturer's instructions. Manual or automatic controls shall be provided that will operate the air curtain with the opening and closing of the door. Air curtains and their controls shall comply with Section C408.2.3.

# 90.1 - Vestibules exceptions

- Non-entrance *doors* or *doors* opening from *dwelling unit*
- *Building entrances* with revolving *doors*
- All *building entrances* in **climate zones 1 and 2** **OR** in *buildings* in **climate zone 3** < 4 stories and < 10,000 ft<sup>2</sup> in gross conditioned floor area **OR** in buildings < 1000 ft<sup>2</sup> in *gross conditioned floor area* in **climate zones 0 and 4-8**
- All *doors* that open from *spaces* < 3000 ft<sup>2</sup> and separate from *building entrance*
- *Semiheated spaces*
- Enclosed elevator lobbies for *building entrances* directly from parking garages

# 90.1 Vestibules for large spaces

- Vestibules opening into large *conditioned spaces* (large retail)
- *spaces* having a *gross conditioned floor area* for that level of the *building* of 40,000 ft<sup>2</sup> and greater,
- and when the *doors* opening into and out of the vestibule are equipped with automatic, electrically driven, self-closing devices, the interior and exterior *doors* shall have a minimum distance between them of not less than 16 ft.

# Section 6 – 6.4.3.9

## Heating and Cooling in Vestibules

- Include automatic controls to
- shut off heating system when
  - OA temps are  $> 45^{\circ}\text{F}$
  - Also controlled by a thermostat in the vestibule with setpoint limited to maximum of  $60^{\circ}\text{F}$

*Note: a single heating thermostat in the vestibule limited to  $45^{\circ}\text{F}$  would meet the requirements*

- Shut off vestibule cooling system when
  - Controlled by a thermostat in the vestibule with setpoint limited to minimum of  $85^{\circ}\text{F}$
- **Exceptions**, vestibules:
  - heated or cooled by site-recovered energy
  - tempered with transfer air that would otherwise be exhausted



# Fenestration



# Fenestration Product rating

- How Do You Meet the Requirement?
- Fenestration product rating in accordance to NFRC 100 (Windows, Doors, Skylights)
- Labeled and certified by the manufacturer
- Non-NFRC 100 rated fenestration
  - Default Glazed Fenestration U-factor Table C303.1.3(1)

|  |   |
|--|---|
| <br>National Fenestration<br>Rating Council<br>CERTIFIED  | <b>World's Best Window Co.</b><br><br>Millennium 2000 <sup>+</sup><br>Vinyl Clad/Wood Frame<br>Double Glazing • Argon Fill • Low E<br>Product Type: Vertical Slider |
| <b>ENERGY PERFORMANCE RATINGS</b>  |   |
| U-Factor (U.S./HP)<br><b>0.35</b>  | Solar Heat Gain Coefficient<br><b>0.32</b>  |
| <b>ADDITIONAL PERFORMANCE RATINGS</b>  |   |
| Visible Transmittance<br><b>0.51</b>   | Air Leakage (U.S./HP)<br><b>0.2</b>   |
| Condensation Resistance<br><b>51</b>   | _____   |
| <small>Manufacturer attests that these ratings conform to applicable NFRC procedures for determining whole product performance. NFRC ratings are determined for a fixed set of environmental conditions and a specific product size. Consult manufacturer's literature for other product performance information.<br/>www.nfrc.org</small> |   |





# NATIONAL FENESTRATION RATING COUNCIL LABEL CERTIFICATE

## PRODUCT LISTING

FOR CODE COMPLIANCE

LABEL CERTIFICATE ID: XYZ-001

Issuance Date: mm/dd/yyyy

### NFRC CERTIFIED PRODUCT RATING INFORMATION:\*

The NFRC Certified Product Rating Information listed here is to be used to verify that the ratings meet applicable energy code requirements.

### PRODUCT LISTING:

| CPD ID   | Total Area<br>ft <sup>2</sup> | Name              | Framing Ref | Glazing Ref | Spacer Ref | CERTIFIED Performance Rating<br>at NFRC<br>Model Size |        |      |
|----------|-------------------------------|-------------------|-------------|-------------|------------|---|--------|------|
|          |                               |                   |             |             |            | U**<br>Btu/<br>hr·ft <sup>2</sup> ·°F                 | SHGC** | VT** |
| P-PL-010 | 88.89                         | PL-2200 / PL-2210 | FA-PL2210   | GA-TT-001   | SA-AM-001  | 0.53  | 0.58   | 0.66 |
| P-PL-005 | 192.67                        | PL-3400 / PL-3401 | FA-PL3401   | GA-TT-001   | SA-AM-002  | 0.56  | 0.57   | 0.65 |
| P-PL-012 | 382.22                        | PL-5700 / PL-5720 | FA-PL5720   | GA-TO-002   | SA-AM-001  | 0.52  | 0.21   | 0.30 |
| P-PL-002 | 60.00                         | PL-1100 / PL-1152 | FA-PL1152   | GA-TT-001   | SA-AM-001  | 0.42  | 0.51   | 0.62 |
| P-PL-022 | 525.00                        | PL-9900 / PL-9915 | FA-PL9915   | GA-TO-003   | SA-AM-002  | 0.45  | 0.15   | 0.19 |

### FRAME, GLAZING and SPACER ASSEMBLIES:

#### FRAMING LISTING:

| FRAMING REF | SUPPLIER ID | DESCRIPTION                                   |
|-------------|-------------|---|
| FA-PL2210   |             | Single Casement Thermally Broken Aluminum     |
| FA-PL3401   |             | Projecting (Awning) Thermally Broken Aluminum |
| FA-PL5720   |             | Vertical Slider PVC reinforced with Steel     |
| FA-PL1152   |             | Vertical Slider Thermally Broken Aluminum     |
| FA-PL9915   |             | Fixed Thermally Broken Aluminum               |

#### GLAZING LISTING:

| GLAZING REF | SUPPLIER ID | DESCRIPTION   |
|-------------|-------------|---|
| GA-TT-001   |             | 1" Double Glazed, 1/4" HC Low-e, 1/4" Clear, Argon (90%), 1/2" gap        |
| GA-TT-002   |             | 1" Triple Glazed, 1/8" Clear, Coated film, 1/8" SC, Argon (90%), 3/8" gap |
| GA-TT-003   |             | 1" Double Glazed, 1/4" Bronze, 1/4" SC Low-e, Argon (90%), 1/2" gap       |

#### SPACER LISTING:

| SPACER REF | SUPPLIER ID | DESCRIPTION                                  |
|------------|-------------|--|
| SA-AM-001  |             | 250P Mill Finish Aluminum Low profile (1/2") |
| SA-AM-002  |             | 15A Polymer Spacer (3/8")                    |



# ASHRAE fenestration requirements for CZ4



|   | <i>Nonresidential</i>  |                           |                              | <i>Residential</i>     |                           |                              | <i>Semiheated</i>      |                           |                              |
|---|------------------------|---------------------------|------------------------------|------------------------|---------------------------|------------------------------|------------------------|---------------------------|------------------------------|
| <i>Fenestration</i>                             | <i>Assembly Max. U</i> | <i>Assembly Max. SHGC</i> | <i>Assembly Min. VT/SHGC</i> | <i>Assembly Max. U</i> | <i>Assembly Max. SHGC</i> | <i>Assembly Min. VT/SHGC</i> | <i>Assembly Max. U</i> | <i>Assembly Max. SHGC</i> | <i>Assembly Min. VT/SHGC</i> |
| <i>Vertical Fenestration, 0% to 40% of Wall</i> |                        |                           |                              |                        |                           |                              |                        |                           |                              |
| <i>Fixed</i>                                    | 0.36                   | 0.36                      | 1.10<br>(for all types)      | 0.36                   | 0.36                      | 1.10<br>(for all types)      | 0.50                   | NR<br>(for all types)     | NR<br>(for all types)        |
| <i>Operable</i>                                 | 0.45                   | 0.33                      |                              | 0.45                   | 0.33                      |                              | 0.65                   |                           |                              |
| <i>Entrance door</i>                            | 0.63                   | 0.33                      |                              | 0.63                   | 0.33                      |                              | 0.77                   |                           |                              |
| <i>Skylight, 0% to 3% of Roof</i>               |                        |                           |                              |                        |                           |                              |                        |                           |                              |
| <i>All types</i>                                | 0.50                   | 0.40                      | NR                           | 0.50                   | 0.40                      | NR                           | 0.75                   | NR                        | NR                           |



# IECC fenestration requirements

TABLE C402.4 BUILDING ENVELOPE FENESTRATION MAXIMUM U-FACTOR AND SHGC REQUIREMENTS

| CLIMATE ZONE          | 0 AND 1 |          | 2     |          | 3     |          | 4 EXCEPT MARINE              |          | 5 AND MARINE 4 |          | 6     |          | 7     |          | 8     |          |
|-----------------------|---------|----------|-------|----------|-------|----------|------------------------------|----------|----------------|----------|-------|----------|-------|----------|-------|----------|
|                       |         |          |       |          |       |          | <b>Vertical fenestration</b> |          |                |          |       |          |       |          |       |          |
|                       |         |          |       |          |       |          | <b>U-factor</b>              |          |                |          |       |          |       |          |       |          |
| Fixed fenestration    | 0.50    |          | 0.45  |          | 0.42  |          | 0.36                         |          | 0.36           |          | 0.34  |          | 0.29  |          | 0.26  |          |
| Operable fenestration | 0.62    |          | 0.60  |          | 0.54  |          | 0.45                         |          | 0.45           |          | 0.42  |          | 0.36  |          | 0.32  |          |
| Entrance doors        | 0.83    |          | 0.77  |          | 0.68  |          | 0.63                         |          | 0.63           |          | 0.63  |          | 0.63  |          | 0.63  |          |
|                       |         |          |       |          |       |          | <b>SHGC</b>                  |          |                |          |       |          |       |          |       |          |
|                       | Fixed   | Operable | Fixed | Operable | Fixed | Operable | Fixed                        | Operable | Fixed          | Operable | Fixed | Operable | Fixed | Operable | Fixed | Operable |
| PF < 0.2              | 0.23    | 0.21     | 0.25  | 0.23     | 0.25  | 0.23     | 0.36                         | 0.33     | 0.38           | 0.33     | 0.38  | 0.34     | 0.40  | 0.36     | 0.40  | 0.36     |
| 0.2 ≤ PF < 0.5        | 0.28    | 0.25     | 0.30  | 0.28     | 0.30  | 0.28     | 0.43                         | 0.40     | 0.46           | 0.40     | 0.46  | 0.41     | 0.48  | 0.43     | 0.48  | 0.43     |
| PF ≥ 0.5              | 0.37    | 0.34     | 0.40  | 0.37     | 0.40  | 0.37     | 0.58                         | 0.53     | 0.61           | 0.53     | 0.61  | 0.54     | 0.64  | 0.58     | 0.64  | 0.58     |
|                       |         |          |       |          |       |          | <b>Skylights</b>             |          |                |          |       |          |       |          |       |          |
| U-factor              | 0.70    |          | 0.65  |          | 0.55  |          | 0.50                         |          | 0.50           |          | 0.50  |          | 0.44  |          | 0.41  |          |
| SHGC                  | 0.30    |          | 0.30  |          | 0.30  |          | 0.40                         |          | 0.40           |          | 0.40  |          | NR    |          | NR    |          |

NR = No Requirement. PF = Projection Factor.

# Fenestration Product rating

- Unlabeled fenestration is required to use the default U-factor and SHGC values.

**Table A8.2 Assembly U-Factors, Assembly SHGCs, and Assembly Visible Transmittances (VTs) for Unlabeled Vertical Fenestration**

| Frame Type                        | Glazing Type   | Unlabeled Vertical Fenestration |      |      |              |      |      |
|-----------------------------------|----------------|---------------------------------|------|------|--------------|------|------|
|                                   |                | Clear Glass                     |      |      | Tinted Glass |      |      |
|                                   |                | U-Factor                        | SHGC | VT   | U-Factor     | SHGC | VT   |
| All frame types                   | Single glazing | 1.25                            | 0.82 | 0.76 | 1.25         | 0.70 | 0.58 |
|                                   | Glass block    | 0.60                            | 0.56 | 0.56 | NA           | NA   | NA   |
| Wood, vinyl, or fiberglass frames | Double glazing | 0.60                            | 0.59 | 0.64 | 0.60         | 0.42 | 0.39 |
|                                   | Triple glazing | 0.45                            | 0.52 | 0.57 | 0.45         | 0.34 | 0.21 |
| Metal and other frame types       | Double glazing | 0.90                            | 0.68 | 0.66 | 0.90         | 0.50 | 0.40 |
|                                   | Triple glazing | 0.70                            | 0.60 | 0.59 | 0.70         | 0.42 | 0.22 |

- Those values are very poor and ***will not comply*** with the prescriptive compliance path.

# Maximum Area

- Fenestration: All areas (including frames) that let in light, including windows, plastic panels, clerestories, skylights, glass doors that are more than half glass, and glass block walls
- The vertical fenestration area shall not be greater than **30 percent** of the gross above-grade wall area.
- The skylight area shall not be greater than 3 percent of the gross roof area.
  - Can increase skylight area to **5 percent** with the use of daylight responsive lighting controls

# Increased Fenestration Area

- In Climate Zones 1 through 6, not more than **40 percent** of the gross above-grade wall area shall be permitted to be vertical fenestration, provided **all** of the following requirements are met:
  1. 1-2 story buildings - At least 50 percent of the net floor area is within a daylight zone.
  2. 3 stories or more - At least 25 percent of the net floor area is within a daylight zone.
  3. Daylight responsive controls complying with Section C405.2.3.1 are installed in daylight zones.
  4. Visible transmittance (VT) of vertical fenestration is not less than 1.1 times solar heat gain coefficient (SHGC).

# Maximum Area

- Fenestration: Skylights, roof windows, vertical windows (fixed or moveable), *opaque doors*, glazed doors, glazed block, and combination opaque/glazed doors
- The vertical fenestration area shall not be greater than **40 percent** of the gross above-grade wall area.
- The skylight area shall not be greater than 3 percent of the gross roof area.
  - Can increase skylight area to **6 percent** with the use of daylight responsive lighting controls

# Maximum Skylight Area

- **IECC**
  - Can increase skylight area from 3 percent to **5 percent** with the use of daylight responsive lighting controls
- **ASHRAE**
  - Can increase skylight area from 3 percent to **6 percent** with the use of daylight responsive lighting controls





# 90.1 Daylighting Details



- 5.5.4.2.2 Max. Skylight Fenestration Area
  - Total skylight area shall not exceed 3% of gross roof area
  - May go to 6% of gross roof area provided design meets all criteria
- 5.5.4.2.3 Minimum Skylight Fenestration Area
  - for any enclosed space in a building (all of the following):
    - $\geq 2,500$  sq. ft.
    - Directly under a roof with ceiling heights greater than 15 feet
    - One of the following space types: office, lobby, atrium, concourse, corridor, warehouse, gym, convention center, courtroom automotive service, fire station engine room, manufacturing, retail, library, distribution/sorting, transportation baggage and seating, or workshop
  - Minimum 50% of floor area is daylit area and either:
    - Provide skylight to daylight area of 3% and VT of 0.4
    - Minimum skylight effective aperture of 1%
  - Many exceptions based on LPD, space type, and side daylighting

---

## Exceptions to Section 5.5.4.2.3

1. *Enclosed spaces in Climate Zones 6 through 8*
2. *Enclosed spaces where it is documented that existing structures or natural objects block direct-beam sunlight on at least half of the roof over the enclosed space for more than 1500 daytime hours per year between 8 a.m. and 4 p.m.*
3. *Enclosed spaces where the daylight area under roof monitors is greater than 50% of the enclosed space floor area.*
4. *Enclosed spaces where it is documented that 90% of the skylight area is shaded on June 21 in the Northern Hemisphere (December 21 in the Southern Hemisphere) at noon by permanent architectural features of the building.*
5. *Enclosed spaces where the total area minus the primary sidelighted area and secondary sidelighted area is less than 2500 ft<sup>2</sup> and where the lighting is controlled according to sidelighting requirements described in Section 9.4.1.1(e).*

# Projection Factor (PF)

- The ratio of overhang projection divided by height from windowsill to bottom of overhang (must be permanent)

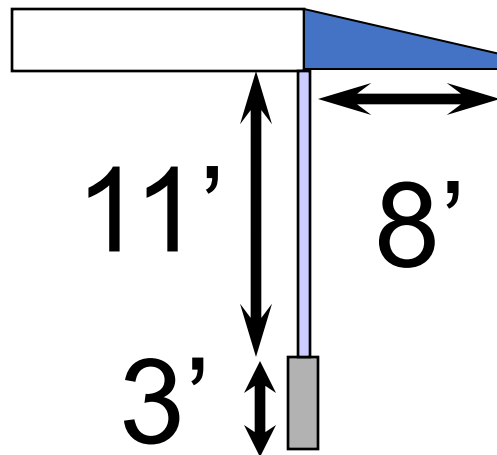

$$PF = 8/11 = 0.73$$

For S, E or W glazing  
SHGC multiplier  
(from next slide) =  
**0.51**

If glass SHGC = 0.48, it effectively becomes 0.24 due to overhang

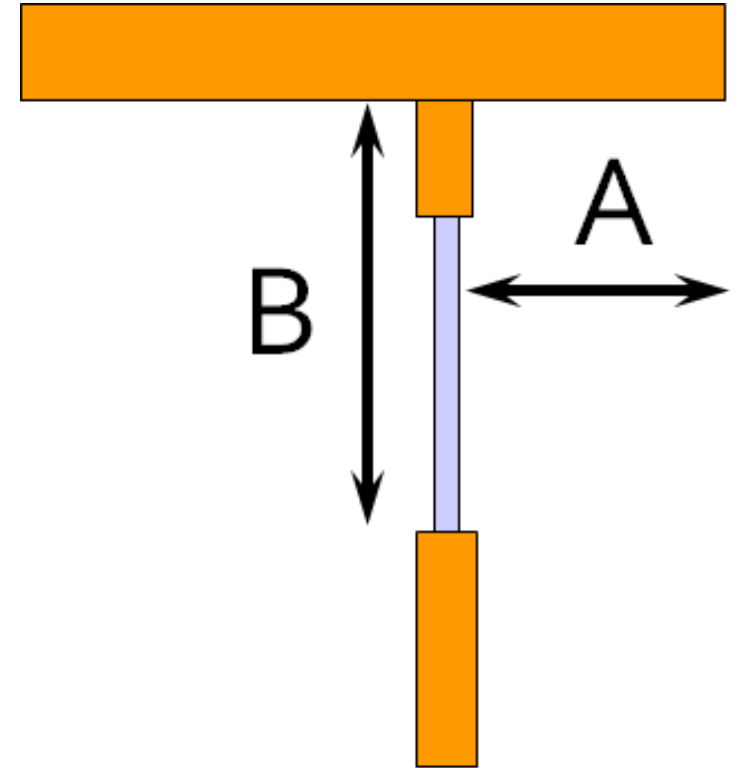

$$PF = A/B$$

# Overhangs

Must be permanent!

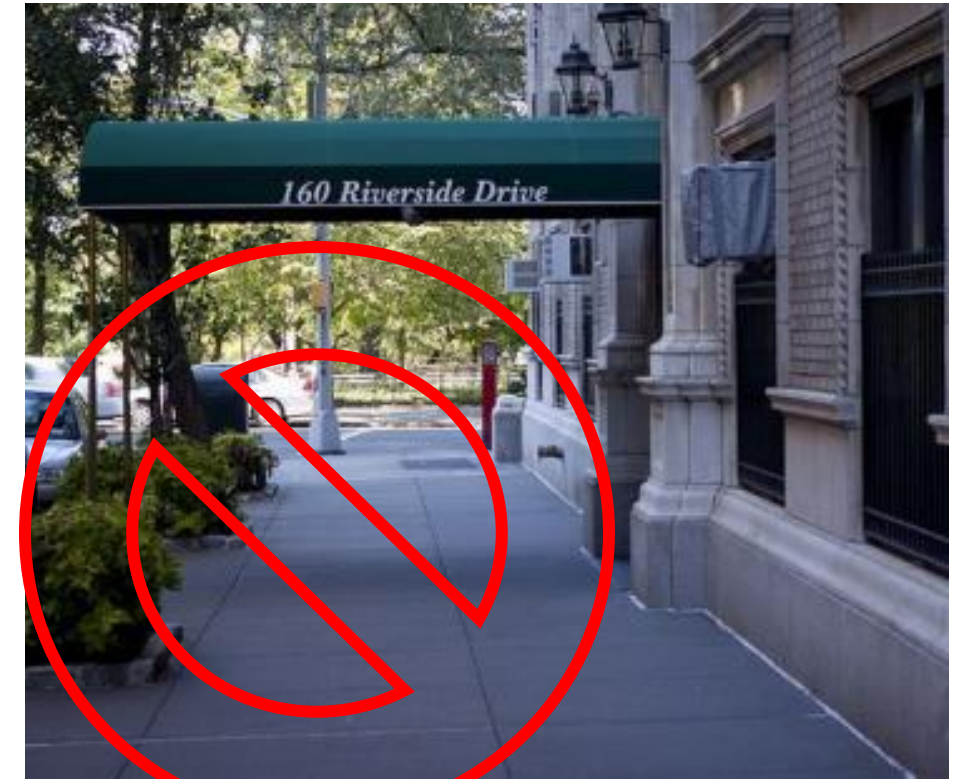

# Fenestration Orientation

- Area of vertical fenestration on east and west facades may not exceed 25% of total area of vertical glazing with some exceptions for permanent shading



## Section 5.5.4.6: VT/SHGC ratio

- Where automatic daylighting controls are required, the Visible Transmittance / SHGC ratio shall be not less than 1.0.

### Exceptions to Section 5.5.4.6

1. A *light-to-solar-gain ratio (LSG)* of not less than 1.25 is allowed to be used as an alternative to *VT/SHGC*. When using this option, the center-of-glass *VT* and the center-of-glass *SHGC* shall be determined in accordance with NFRC 300 and NFRC 301, determined by an independent laboratory or included in a database published by a government agency, and certified by the *manufacturer*.
2. *Fenestration* not covered in the scope of the NFRC 200.
3. *Enclosed spaces* where the *daylight area under roof monitors* is greater than 50% of the *enclosed space floor area*.
4. *Enclosed spaces* with *skylights* that comply with Section [5.5.4.2.3](#).
5. *Enclosed spaces* where the *sidelighting effective aperture* is greater than or equal to 0.15.
6. For *dynamic glazing*, the *VT/SHGC* ratio and the *LSG* shall be determined using the maximum *VT* and maximum *SHGC*. *Dynamic glazing* shall be considered separately from other *fenestration*, and area-weighted averaging with other *fenestration* that is not *dynamic glazing* shall not be permitted.

# ENERGY CODE TRAINING

## Building Envelope Trade offs

- Commercial Envelope  
Part 2



# Sweet NEW – using Comcheck

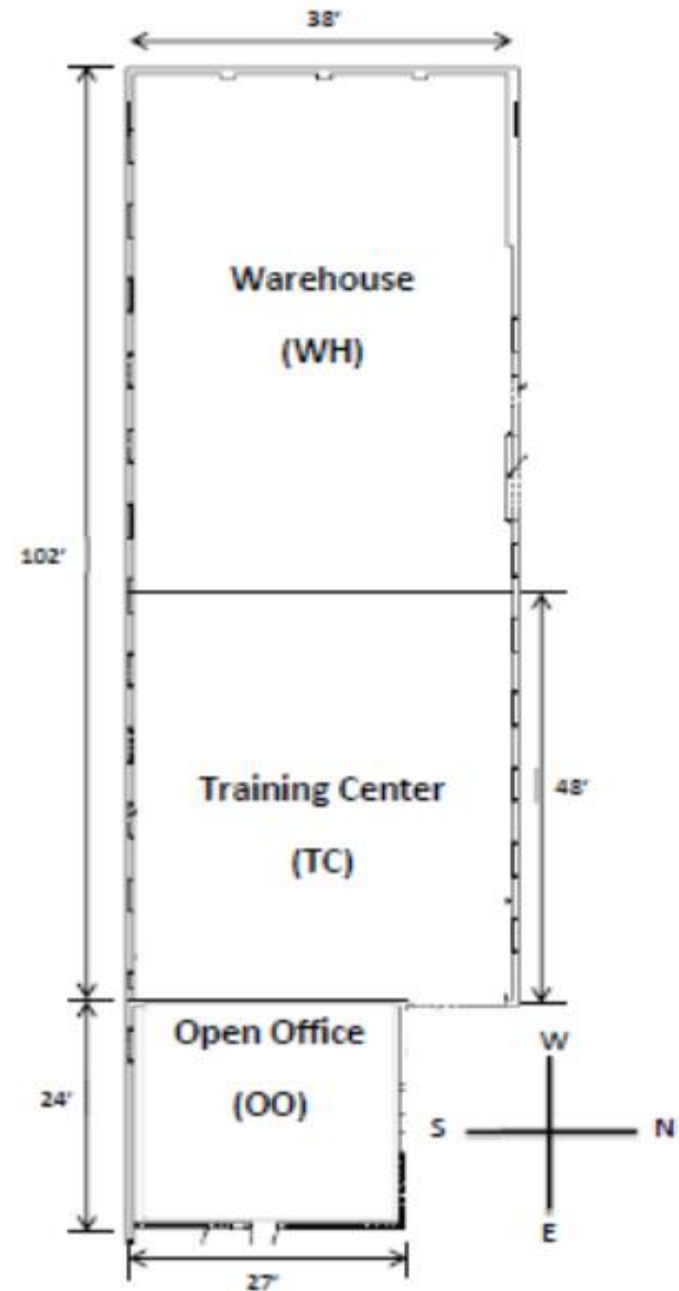



# ComCheck

## Information you will need

- Energy Code Builder and project location
- Area take-offs for envelope assemblies
- Insulation R-values, fenestration performance data
- Lighting fixture details
- Heating and cooling system details
- Service water heating details



# Comcheck

- Go to [www.energycodes.gov](http://www.energycodes.gov) and pull up COMCheck web
- – establish a user's account & feel free to play with it

# Prescriptive Glazing Example

- **Small Retail Building**
- All metal curtain-wall glazing is on the Front (East) façade and shaded by a 6' overhang
- Option 1:
- Glazing U = 0.50, SHGC = 0.52
- Option 2:
- Glazing U = 0.36, SHGC = 0.44
- *Does either option comply with the CZ5 prescriptive glazing requirements of 90.1-2016?*

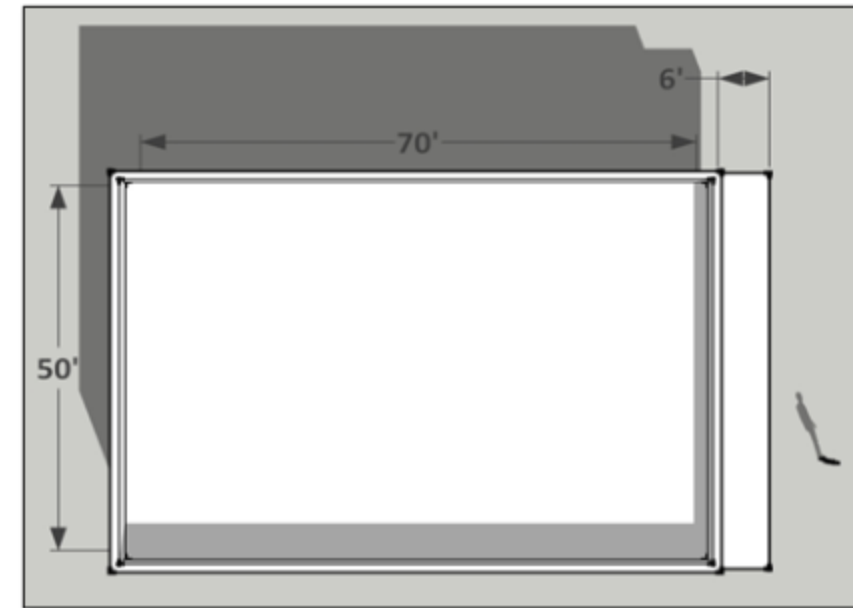
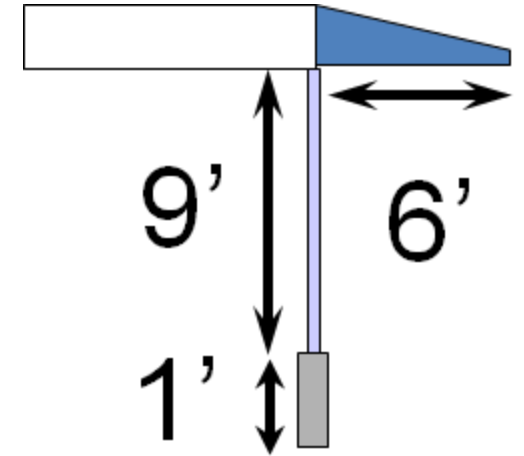

# Daylight Area - skylights

- Daylight area: the floor area substantially illuminated by natural daylight

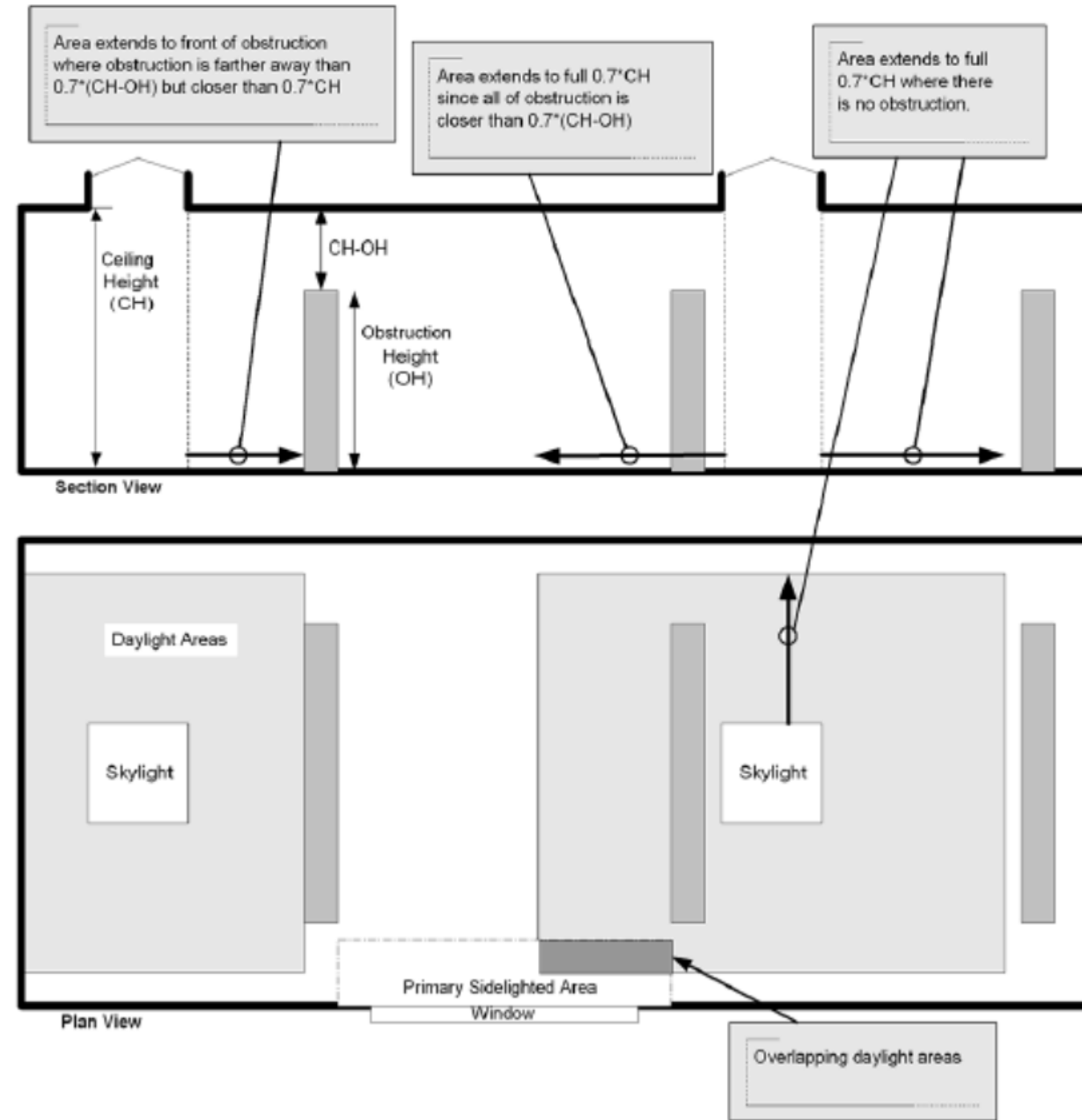

**daylight area under skylights:** the *daylight area under skylights* is the combined *daylight area* under each *skylight* within a *space*. The *daylight area* under each *skylight* is bounded by the opening beneath the *skylight* and horizontally in each direction (see Figure 3.2-2), the smaller of

- 70% of the ceiling height ( $0.7 \times CH$ ) or
- the distance to the nearest face of any *opaque* vertical obstruction, where any part of the obstruction is farther away than 70% of the distance between the top of the obstruction and the ceiling ( $0.7 \times [CH - OH]$ , where  $CH$  = the height of the ceiling at the lowest edge of the *skylight* and  $OH$  = the height to the top of the obstruction).

# Daylight Zones

- Skylights: 45° angle from skylight at ceiling height (CH); extend outward from skylight ground projection by 0.7xCH)
- Windows: 15' inward from vertical glazing
- Windows: width + 2'

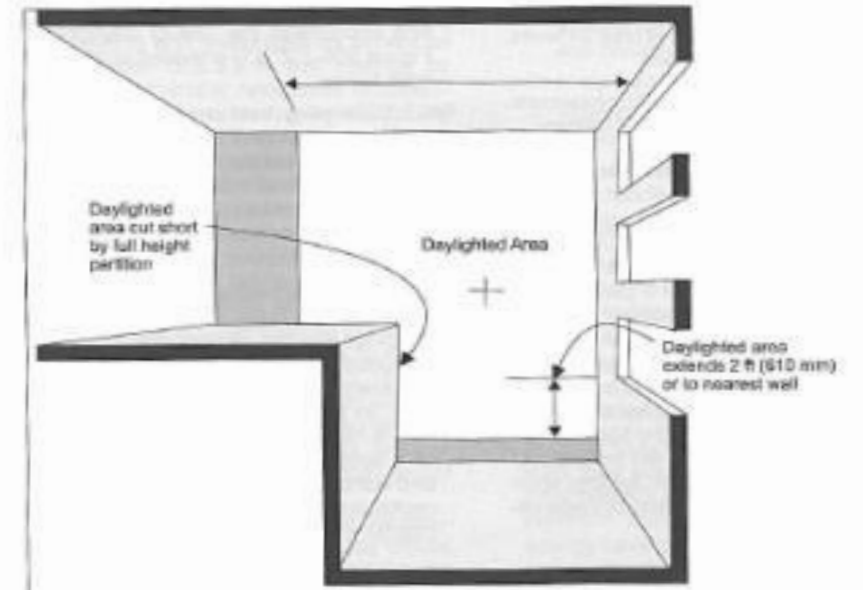
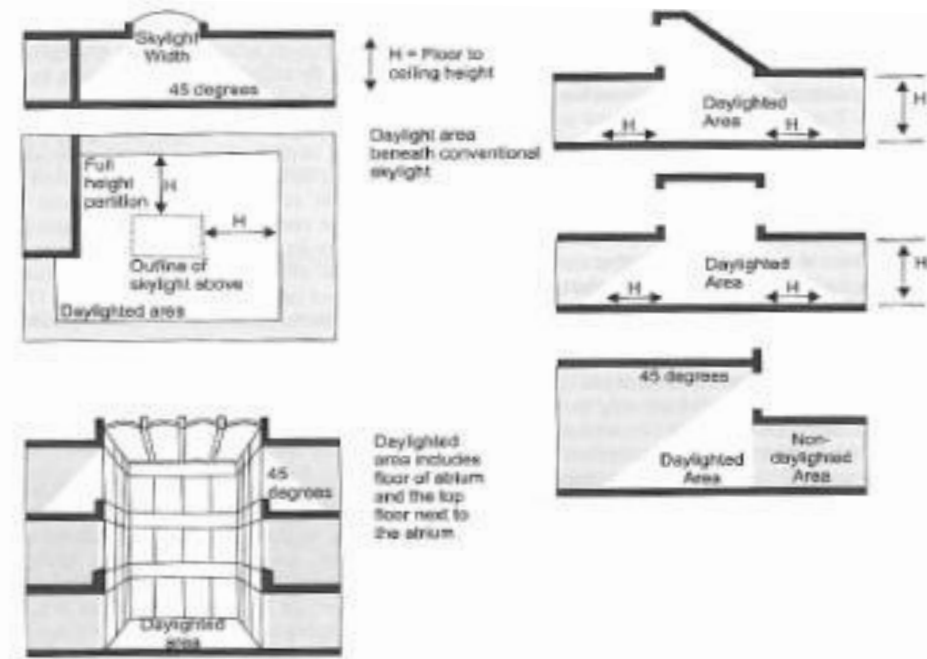

# Enhanced Envelope Performance - Optional

Total UA of building thermal envelope as designed to be not less than 15% below total UA of building thermal envelope per Section C402.1.5 – Component performance alternative.

# Air Sealing Testing Compliance Options

1. Whole-Building Testing
2. Materials Testing
3. Assemblies of Materials Testing

# Option 1: Whole-Building Testing: $\leq 0.40$ CFM<sub>75</sub>/ft<sup>2</sup>



Buildings > 50,000 sf

Can comply by testing only (and all) the following portions and area-weighting measured air leakage:

- a) Floor areas under roof or with building entrances
- b) Representative above-grade wall sections totaling at least 25% of wall area, not including floor area above

Buildings < 50,000 sf

Must comply by testing entire building



# Option 2: Materials Testing

- Acceptable materials must have an air permeance of  $<0.004$  cfm/ft<sup>2</sup> under pressure differential of 0.3 in. of H<sub>2</sub>O when tested in accordance with ATM E 2178

| Material   | Thickness (minimum) |
|--|---------------------|
| Plywood  | 3/8 in.             |
| Oriented strand board  | 3/8 in.             |
| Extruded polystyrene insulation board                                    | 1/2 in.             |
| Foil-faced urethane insulation board                                     | 1/2 in.             |
| Exterior gypsum sheathing or interior gypsum board                       | 1/2 in.             |
| Cement board   | 1/2 in.             |
| Built up roofing membrane  |                     |
| Modified bituminous roof membrane  |                     |
| Single-ply roof membrane   |                     |
| A Portland cement/sand parge, stucco, or gypsum plaster                  | 1/2 in.             |
| Cast-in-place and precast concrete                                       |                     |
| Sheet metal  |                     |
| Closed cell 2 lb/ft <sup>3</sup> nominal density spray polyurethane foam | 1 in.               |



# Option 3: Assemblies Testing

Assemblies of materials and components (sealants, tapes, etc.) that have an average air leakage  $<0.04$  cfm/ft<sup>2</sup> under a pressure differential of 0.3 in. of H<sub>2</sub>O when tested in accordance with ASTM E 2357, 1677, 1680, or 283.

The following assemblies meet these requirements:

Concrete masonry walls that are

- Fully grouted, or
- Painted to fill the pores.

# 2024 National Energy Standard

- In Process since November '21
- Use '21 Energy Code as Basis and Improvements from there.
- Many more stakeholders than IECC Development
- Glide slope to Net Zero by 2030
- Expanded Appendices
- Carbon Impact



# Questions?





# Upcoming Events

## Nebraska Energy Code: The 2021 IECC & IECC-R Overview

- March 6th – 11:00am to 12:30 CT

## Coming in April!

Nebraska Collaborative Meeting – **Date TBD**

Tour of New Medical Facilities Construction Univ of Nebraska-Kearney

Tour de Nebraska! (It's like "Door-Dash Code Training"!)





# Thank you!

Matt Belcher, Verdatek Solutions

[matt@verda-solutions.com](mailto:matt@verda-solutions.com)

Cell: (314) 749-4189

John Gossman, MEEA

[jgossman@mwalliance.org](mailto:jgossman@mwalliance.org)

